

T100 Series Low Pressure Models T100E, T100F & T100H

Maximum Flow Rate: 96 gpm (366.1 l/min) 3292 BPD
Maximum Pressure: 2100 psi (145 bar)

Hydra-Cell[®]
Seal-less Pumps



T100 Series low-pressure model with Nickel Aluminum Bronze (NAB) pump head.

**Available
to Meet
API 674!**

- Seal-less design separates the power end from the process fluid end, eliminating leaks, hazards, and the expense associated with seals and packing.
- Low NPSH requirements allow for operation with a vacuum condition on the suction - positive suction pressure is not necessary.
- Can operate with a closed or blocked suction line and run dry indefinitely without damage, eliminating downtime and repair costs.
- Unique diaphragm design handles more abrasives with less wear than gear, screw or plunger pumps.
- Hydraulically balanced diaphragms to handle high pressures with low stress.
- Lower energy costs than centrifugal pumps and other pump technologies.
- Rugged construction for long life with minimal maintenance.
- Compact design and double-ended shaft provide a variety of installation options.

T100 Series Low Pressure Performance

Capacities

Model	Max. Input rpm	Plunger Dia.		Max. Flow Capacities			Max. Pressure Ratings Discharge		Max. Pressure Ratings Inlet	
		Inches	mm	gpm	l/min	BPD	psi	bar	psi	bar
T100E	450	2.500	64	96.0	366.1	3292	1500	103	500	34
T100F	450	2.250	57	76.5	289.6	2623	1850	128	500	34
T100H	450	2.125	54	68.0	257.8	2332	2100	145	500	34

Consult factory when operating below 45 rpm.

Maximum Flow at Designated Pressure

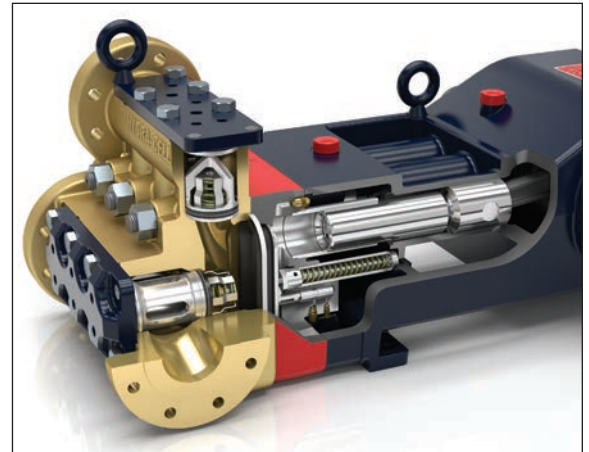
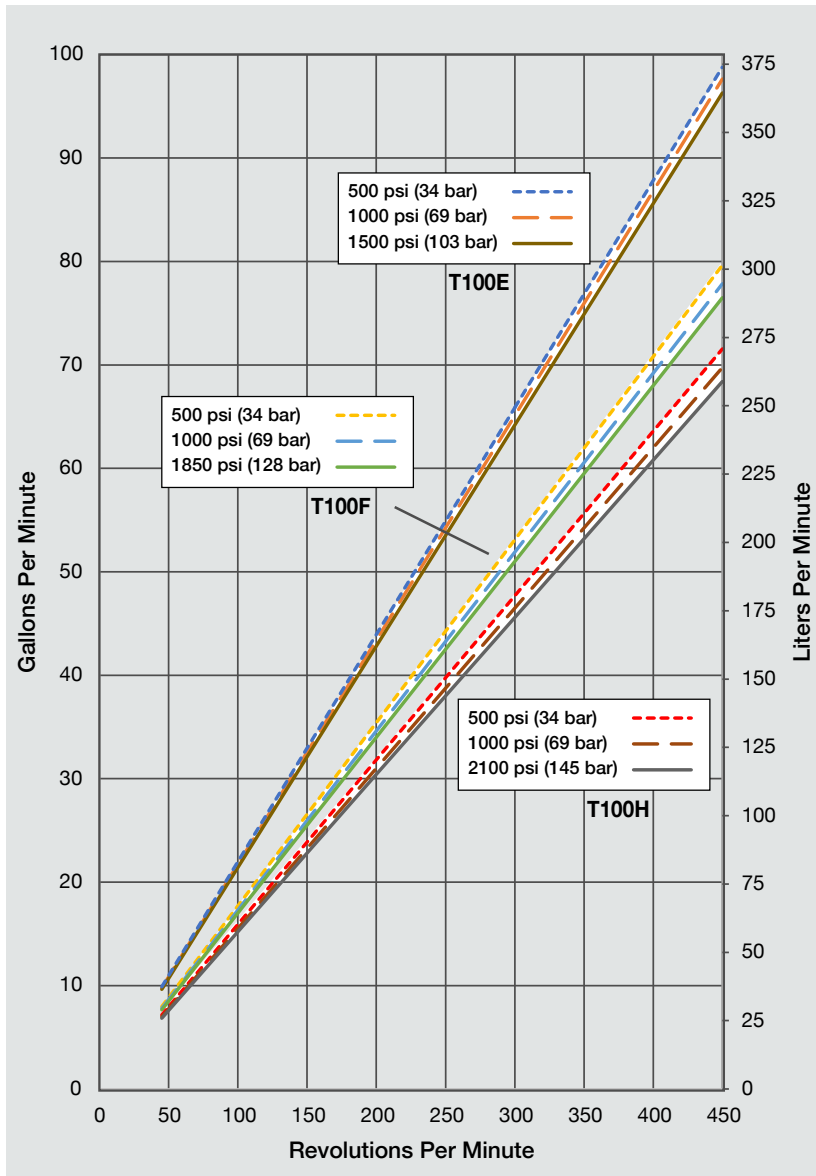

T100 Series pumps feature the Hydra-Cell seal-less design, eliminating clean-up costs from leaking seals or packing and protecting operators from dangerous fluids such as those containing hydrogen sulfide.

Net Positive Suction Head (NPSHr)

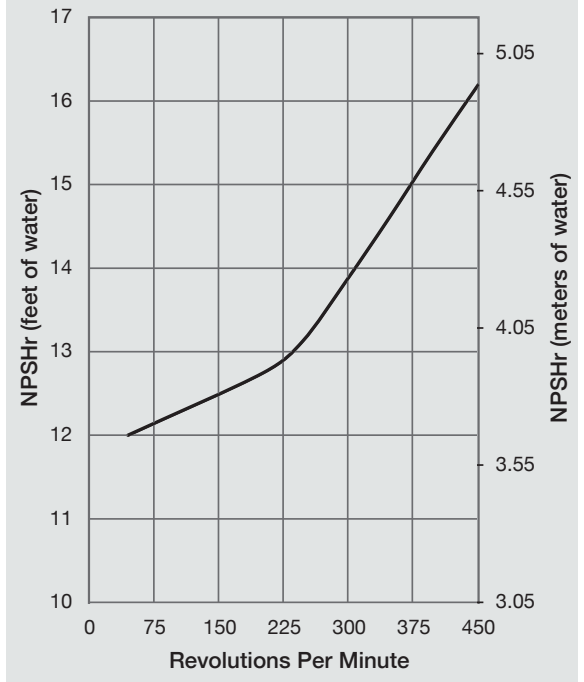

Due to the Wanner Engineering Continuous Improvement Program, specifications and other data are subject to change.

T100 Series Low Pressure Specifications

Flow Capacities

Model	Pressure psi (bar)	rpm	gpm	l/min	BPD
T100E	1500 (103)	450	96.0	366.1	3292
T100F	1850 (128)	450	76.5	289.6	2623
T100H	2100 (145)	450	68.0	257.8	2332

Delivery

	Pressure psi (bar)	gal/rev	liters/rev
T100E	500 (34)	0.220	0.831
	1000 (69)	0.217	0.821
	1500 (103)	0.214	0.809
T100F	500 (34)	0.177	0.669
	1000 (69)	0.173	0.655
	1850 (128)	0.170	0.644
T100H	500 (34)	0.159	0.601
	1000 (69)	0.155	0.587
	2100 (145)	0.152	0.575

rpm

Maximum:	450
Maximum API 674:	375
Minimum:	45 (Consult factory for speeds less than 45 rpm.)

Maximum Discharge Pressure

Metallic Heads:	T100E	1500 psi (103 bar)
	T100F	1850 psi (128 bar)
	T100H	2100 psi (145 bar)

Maximum Inlet Pressure

500 psi (34 bar)

Operating Temperature

Maximum:	180 °F (82.2 °C)
Minimum:	40 °F (4.4 °C)

Consult factory for temperatures outside this range.

Maximum Solids Size

800 microns

Input Shaft

Left or Right Side

Inlet Ports

3-1/2 inch Class 300 RF ANSI Flange

Discharge Ports

2 inch Class 900 RF ANSI Flange

Plunger Stroke Length

3-1/2 inch (88.9 mm)

Shaft Diameter

3 inch (76.2 mm)

Shaft Rotation

Uni-directional (See rotation arrow.)

Oil Capacity

18 US quarts (17 liters) - blank back cover
20.5 US quarts (19.4 liters) - oil level back cover
See page 5 for oil selection and specification.

Weight

Metallic Heads: 1100 lbs. (499 kg)

Calculating Required Horsepower (kW)*

$$\frac{\text{gpm} \times \text{psi}}{1,460} = \text{electric motor hp}^*$$

$$\frac{\text{lpm} \times \text{bar}}{511} = \text{electric motor kW}^*$$

* hp (kW) is required application power.

Attention!

When sizing motors with variable speed drives (VFD): It is very important to select a motor and a VFD rated for constant torque inverter duty service and that the motor is rated to meet the torque requirements of the pump throughout desired speed range.

Fluid End Materials

Manifold:	Nickel Aluminum Bronze (NAB) Duplex Alloy 2205 Stainless Steel 316L Stainless Steel CF3M Hastelloy CX2M
Diaphragm/Elastomers:	FKM Buna-N Aflas EPDM
Diaphragm Follower Screw:	316 Stainless Steel
Valve Spring Retainer:	316 SST Hastelloy C
Check Valve Spring:	Elgiloy Hastelloy C
Valve Disc/Seat:	Tungsten Carbide 17-4 Stainless Steel Nitronic 50 Hastelloy C
Outlet Valve Retainer:	316 Stainless Steel
Plug-Outlet Valve Port:	316 Stainless Steel
Inlet Valve Retainer:	316 Stainless Steel

Power End Materials

Crankshaft:	Forged Q&T Alloy Steel
Connecting Rods:	Ductile Iron
Crossheads:	12L14 Steel
Crankcase:	Ductile Iron
Bearings:	Spherical Roller/Journal (main) Steel Backed Babbit (crankpin) Bronze (wristpin)

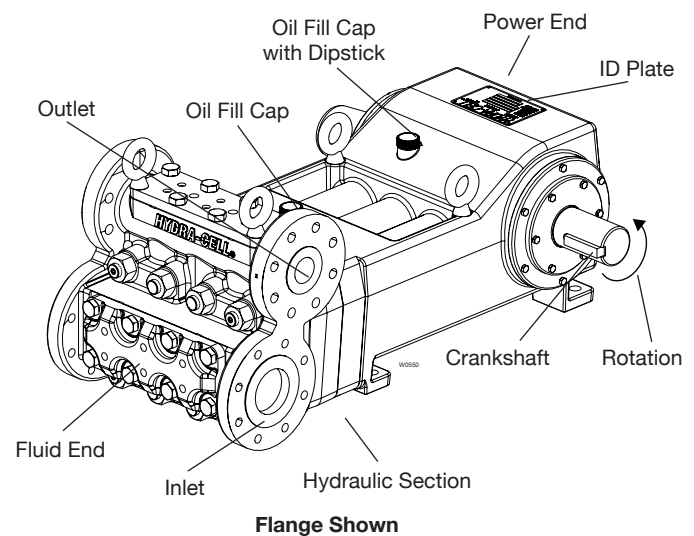

T100 Series Low Pressure Drawings

Flanged Version inches (mm)

Bottom View

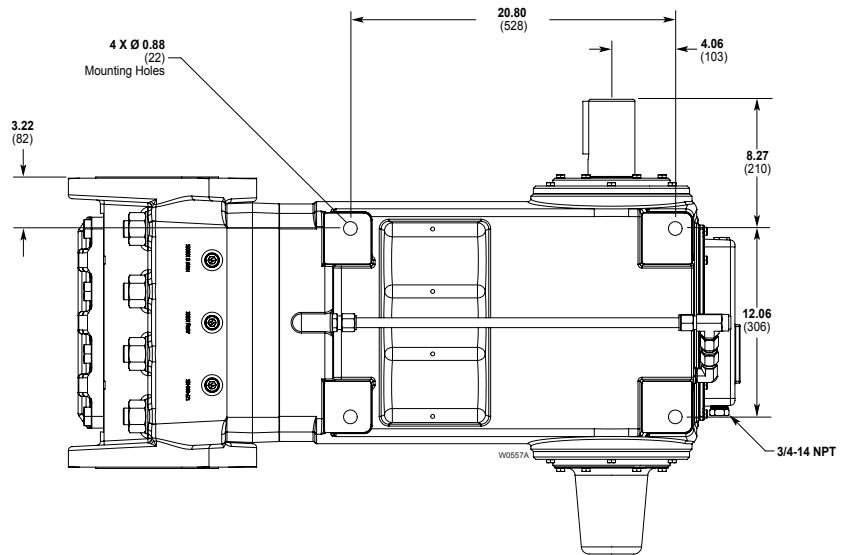

Front View

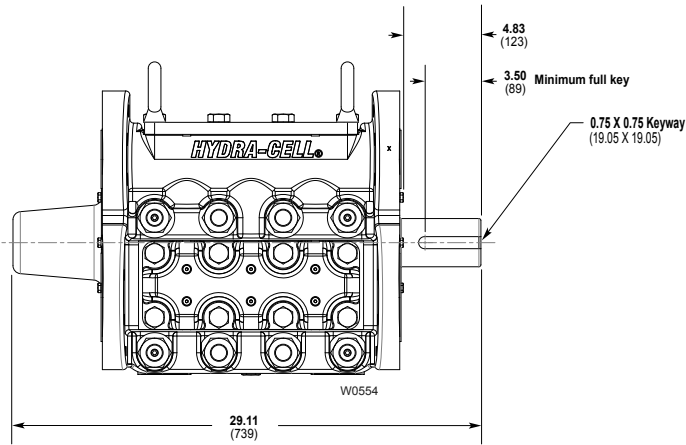

Side View

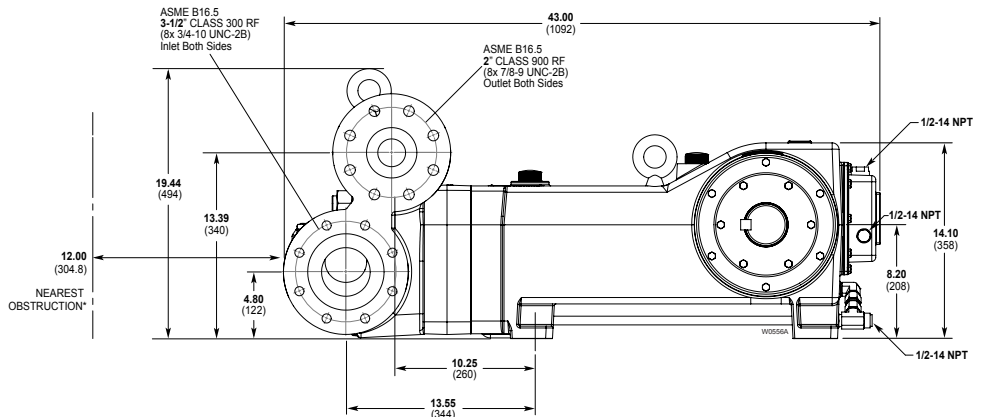

*Contact factory for obstruction distances closer than 12 inches (304.8 mm).

Note: Dimensions are for reference only. Contact factory for certified drawings.

T100 Series Low Pressure How to Order

Ordering Information

1	2	3	4	5	6	7	8	9	10	11	12	13	14
T	1	0	0		R								

A complete T100 Series Low Pressure Model Number contains 14 digits including 9 customer-specified design and materials options, for example: T100ERDGHFESA0.

Low Pressure

Digit	Order Code	Description
1-4	T100	Pump Configuration Shaft-driven
5	E	Performance Max. 96.0 gpm (366.1 l/min) 3292 BPD @ 1500 psi (103 bar)
	F	Max. 76.5 gpm (289.6 l/min) 2623 BPD @ 1850 psi (128 bar)
	H	Max. 68.0 gpm (257.8 l/min) 2332 BPD @ 2100 psi (145 bar)
6	R	Pump Head Version ANSI Flanged Ports (RF on Inlet / RF on Discharge)
7	D	Pump Head Material Nickel Aluminum Bronze (NAB)
	G	Duplex Alloy 2205 Stainless Steel
	S	316L Stainless Steel CF3M
	T	Hastelloy CX2M
8	A	Diaphragm & O-ring Material Aflas
	E	EPDM (requires EPDM-compatible oil - Digit 13 oil code D)
	G	FKM
	T	Buna-N
9	D	Valve Seat Material Tungsten Carbide*
	H	17-4 Stainless Steel
	N	Nitronic 50
	T	Hastelloy C
10	D	Valve Material Tungsten Carbide*
	F	17-4 Stainless Steel
	N	Nitronic 50
	T	Hastelloy C
11	E	Valve Springs Elgiloy
	T	Hastelloy C

Digit	Order Code	Description
12	S	Valve Spring Retainers 316 SST
	T	Hastelloy C
13	A	Hydra-Oil 10W30 standard-duty oil
	B	40-wt. oil
	D	EPDM-compatible oil
	E	Food-contact oil
	H	15W50 high-temp severe-duty synthetic oil
14	C	Oil Level Monitor Cover Float switch, normally closed (recommended)
	O	Float switch, normally open
	S	Float switch, Class I, Div. 1, Groups C & D, normally closed
	T	Float switch, Class I, Div. 1, Groups C & D, normally open
	W	Float switch, ATEX/IECEX, 4-20 mA analog output (qualification required)
	X	Float switch, ATEX/IECEX, 4-20 mA discrete output (qualification required)
	Y	No switch, flat back cover

Note: The Oil Level Monitor Cover is an assembly that replaces the previous back cover on T100 Series pumps. It contains a float switch assembly that can trigger an alarm or shutdown when pre-defined levels of high or low oil are reached. It may also be ordered without a float switch cover.

*Tungsten Carbide valve seat and disc are a matched set and must be purchased together.

Hydra-Cell®

Seal-less Pumps

Wanner Engineering, Inc.

World Headquarters & Manufacturing

Wanner Engineering, Inc.
1204 Chestnut Avenue
Minneapolis, MN 55403 USA
Phone: 612-332-5681 • Fax: 612-332-6937
Toll-Free Fax (USA): 800-332-6812
Email: sales@wannereng.com
www.Hydra-Cell.com

Regional Office

207 US Highway 281
Wichita Falls, TX 76310 USA
Phone: 940-322-7111
Toll-Free: 800-234-1384
Email: sales@wannereng.com
www.Hydra-Cell.com

Latin American Office

Avenida Senador Vergueiro 608 - Centro
São Bernardo do Campo/São Paulo, Brazil
CEP 09750-000
Phone: +55 (11) 99582-1969
Email: mmagoni@wannereng.com
www.Hydra-Cell-Pumps.com.br

Wanner International Ltd.

Wanner International, Ltd.
Hampshire - United Kingdom
Phone: +44 (0) 1252 816847
Email: sales@wannerint.com
www.Hydra-Cell.co.uk

Wanner Pumps Ltd.

Wanner Pumps, Ltd.
Kowloon - Hong Kong
Phone: +852 3428 6534
Email: sales@wannerpumps.com
www.WannerPumps.com

Shanghai - China
Phone: +86-21-6876 3700
Email: sales@wannerpumps.com
www.WannerPumps.com

