



# Advanced Energy Saving Compressed Air Filters

PPF SERIES 20 to 1500 scfm (34 to 2459 nm<sup>3</sup>/h)



Since 1946, the world has turned to PNEUMATIC PRODUCTS for the quality and service demanded by the most critical of applications. Global leaders of industry require durable components that deliver unquestionable reliability. Our precision engineered components and designs deliver outstanding service life and operational longevity. Invest in our experience and gain annuities that will grow for years.

Based in Charlotte, North Carolina, SPX Corporation (NYSE: SPW) is a global Fortune 500 multi-industry manufacturing leader with over \$5 billion in annual revenue, operations in more than 35 countries and over 15,000 employees. The company's highly-specialized, engineered products and technologies are concentrated in Flow Technology and energy infrastructure. Many of SPX's innovative solutions are playing a role in helping to meet rising global demand for electricity and processed foods and beverages, particularly in emerging markets. The company's products include food processing systems for the food and beverage industry, critical Flow components for oil and gas processing, power transformers for utility companies, and cooling systems for power plants. For more information, please visit [www.spx.com](http://www.spx.com).

## The Next Generation of Compressed Air Filtration

Energy costs continue to escalate globally, having a negative impact on plant profitability and production costs. Sustainability initiatives in plant operations must be implemented to maintain a competitive advantage.

Air treatment manufacturers are challenged to design equipment that is cost effective, delivers optimum performance and consumes less energy. The Pneumatic Products PPF Series Filters are the ideal solution to remove contamination from compressed air systems and save energy.

The PPF Series employs technological advancements in filtration materials and design to ensure premium compressed air quality and low operational costs.

Filters are tested and rated delivering certifiable performance according to ISO 8573.1: 2009 air quality standards.



# Sustainable Energy Savings Solutions...

The development of sustainable energy savings compressed air treatment solutions is the driving principle behind Pneumatic Products product designs. The PPF Series provides the perfect balance between high performance filtration and low pressure drop. Patented filter elements (US 7,618,480 B2) maintain low pressure drop and long service life.

By minimizing resistance to flow, energy costs are significantly reduced. The example demonstrates the effect of pressure drop on operating costs.



## ANNUALIZED COST OF PRESSURE DROP

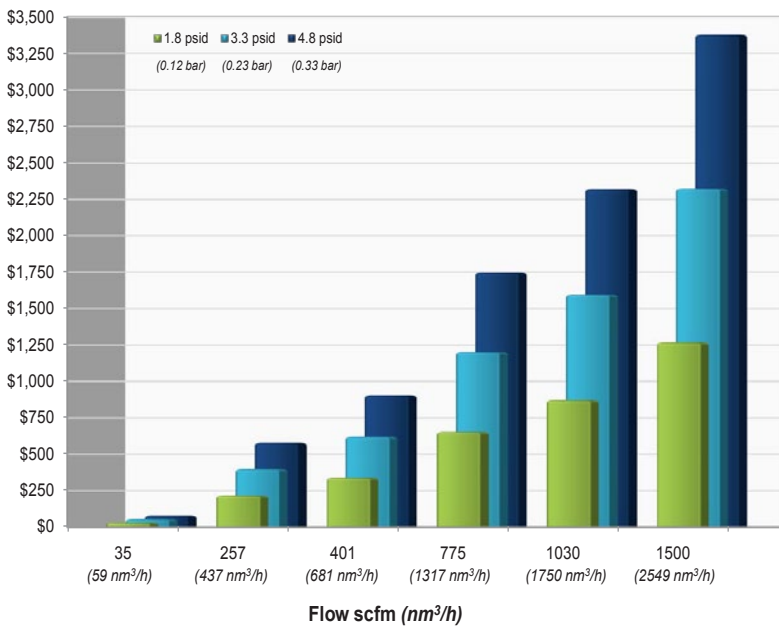

## EXAMPLE:

**Model:** PPF-1030-HC High Performance

Coalescing Filter

**Flow:** 1030 scfm (1750 nm³/h)

**Hours of Operation:** 8000 hours

**Operating Pressure:** 101.5 psig (7 bar)

**Power Cost:** \$0.10/kWh

**Pressure Drop:** 1.8 psid (0.12 bar)

**Cost of Pressure Drop:** \$870/yr

Under identical operation conditions, conventional filters maintain a higher cost of ownership.

### Conventional Filters:

**Pressure Drop:** 3.3 psid (0.23 bar)

**Cost of Pressure Drop:** \$1,596/yr

**Pressure Drop:** 4.8 psid (0.33 bar)

**Cost of Pressure Drop:** \$2,321/yr

## PPF SERIES PRESSURE DROP PERFORMANCE\*

Element Grade	Filter Description	Dry Δp		Wetted Δp	
		psig	bar	psig	bar
SP	Bulk Liquid Separator/Filter	0.8	0.06	1.0	0.07
PR	General Purpose Filter	0.6	0.04	1.4	0.10
HC	High Efficiency Oil Removal Filter	0.6	0.04	1.8	0.12
UC	Ultra High Efficiency Oil Removal Filter	0.8	0.06	2.0	0.14
CB	Oil Vapor Removal Filter	1.0	0.07	-	-

\*Pressure drop not to exceed stated values at ISO 12500 test conditions

# International Standards for Test & Measurement

## ISO 12500

ISO 12500 defines a universal method for manufacturers to test and rate compressed air filters. Critical performance parameters are specified for inlet oil challenge and solid particulate size distribution.

- ISO 12500-1 defines the testing of coalescing filters for oil aerosol removal performance.
- ISO 12500-2 quantifies vapor removal capacity of adsorption filters.
- ISO 12500-3 outlines requirements to test particulate filters for solid contaminant removal.

The PPF Series is tested to ISO 12500. Test results provide certifiable performance data based on defined challenge concentrations.



## PPF SERIES FILTRATION PERFORMANCE

Element Grade	SP	PR	HC	UC	CB
<b>Particle Retention Size<sup>1</sup></b> <i>(Per ISO 12500-3)</i>	3.0 µm	1.0 µm	0.01 µm	0.01 µm	0.01 µm
<b>Particle Removal Efficiency</b> <i>(Per ISO 12500-3)</i>	-	99.999+%	99.999+%	99.9999+%	99.999+%
<b>Oil Removal Efficiency</b> <i>(Per ISO 12500-1)</i>	50%	80%	99.9+%	99.99+%	-
<b>Remaining Oil Content<sup>2</sup></b> <i>(Per ISO 12500-1)</i>	5.0 mg/m <sup>3</sup>	2.0 mg/m <sup>3</sup>	< 0.01 mg/m <sup>3</sup>	< 0.001 mg/m <sup>3</sup>	< 0.004 mg/m <sup>3</sup> (as a vapor)

<sup>1</sup> Solid particulate size distribution 0.01 to 5.0 µm

<sup>2</sup> Inlet oil challenge concentration 10mg/m<sup>3</sup>

## ISO 8573.1:2009 AIR QUALITY STANDARD

ISO 8573, the international standard for compressed air quality, defines the amount of contamination permissible in compressed air.

- The standard identifies three primary forms of contamination in compressed air systems – solid particles, water and oil.
- Contaminants are classified and assigned a quality class, ranging from Class 0, the highest purity level, to Class 9, the most relaxed

### ISO Quality Class 8573.1: 2009

Element Grade	ISO Quality Class Solids	ISO Quality Class Oil
SP	3	5
PR	2	4
HC	1	1
UC	1	1
CB	1	1 <i>(as a vapor)</i>

PPF elements are performance validated to ISO 12500 ensuring air quality delivered is in accordance to ISO 8573.1: 2009 classifications



Air Quality Class	Solid Particles			Water Vapor Pressure		Oil	
	Maximum number of particles per m <sup>3</sup>			Dew Point		Total Oil Concentration: Aerosol, Liquid & Vapor	
	0.10 - 0.5 micron	0.5 - 1.0 micron	1.0 - 5.0 micron	°C	°F	mg / m <sup>3</sup>	ppm <sub>w/w</sub>
<b>0</b>	<b>As specified by the equipment user or supplier and more stringent than class 1</b>						
<b>1</b>	≤ 20,000	≤ 400	≤ 10	≤ -70	≤ -94	0.01	0.008
<b>2</b>	≤ 400,000	≤ 6,000	≤ 100	≤ -40	≤ -40	0.1	0.08
<b>3</b>	-	≤ 90,000	≤ 1,000	≤ -20	≤ -4	1	0.8
<b>4</b>	-	-	≤ 10,000	≤ +3	≤ +37	5	4
<b>5</b>	-	-	≤ 100,000	≤ +7	≤ +45	-	-

# Patented Venturi-Wave™ Element

## ① Patented Venturi-Wave™ Element Design

- The venturi profile promotes a turbulent-free transition for compressed air entering the element
- Optimized flow distribution through the element minimizes pressure loss and reduces system operating cost
- Unique backside contour assists smooth movement of air exiting the filter housing

## ② Deep Bed Pleated, High Performance Media

- Increased effective filtration surface area, reduces pressure drop by 50%
- 96% voids-volume ratio optimizes dirt loading capacity
- HEPA grade micro fiberglass media maximizes efficiency
- Thermally bonded polyester support layers minimize media migration
- Low wetted pressure drop for the life of the element
- Seam welded, stainless steel inner and outer support cores enhance dimensional stability of the element
- Chemically inert, non-aging polyester drain layer expedites removal of liquid
- All materials of construction are silicone free

## ③ Element Grade Identification

- Color coded end caps promote ease of element grade identification
- Bottom end caps pad printed with genuine Pneumatic Products filter element replacement part number



### Element - Materials of Construction

<b>Filter Media</b>	HEPA grade borosilicate fiberglass
<b>Inner/Outer Support Cores</b>	400 Series stainless steel
<b>Drainage Layer</b>	Filtration grade polyester
<b>End Caps</b>	Fiberglass reinforced polyamide resin
<b>Bonding Agent</b>	Polyurethane
<b>End Cap Seal</b>	Nitrile

## & Optimized Housing Design

### ④ Sculpted Design

- Covers flow ranges 20 scfm to 1500 scfm (34 to 2549 nm<sup>3</sup>/h)
- Flanged inlet and outlet connections make installation easy
- Thirteen flow models, with multiple port sizes, 1/4" to 3" NPT, allow for greater application flexibility
- Sculpted housing designs, with large unrestricted flow paths, reduce pressure drop

### ⑤ Safety Built-In

- Die cast aluminium housings provide a cost effective solution in the 1030 to 1500 scfm (1750 to 2549 nm<sup>3</sup>/h) flow range
- Chromated housings, with a polyester epoxy powder coating for corrosion resistance
- Internally ribbed bowls facilitate condensate draining
- Audible alarm when attempting bowl removal under pressure

### Housing - Materials of Construction

<b>Filter Head</b>	Aluminum
<b>Filter Housing</b>	Aluminum
<b>Seals</b>	Nitrile
<b>Chromating Process</b>	Hexavalent-free trivalent
<b>Exterior Coating</b>	Polyester epoxy powder
<b>Manual Drain</b>	Brass body, Viton <sup>®</sup> seal
<b>Internal Float Drain</b>	Polyacetal float, Brass body, Viton <sup>®</sup> seal and stainless steel springs











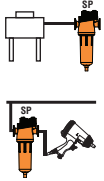

# Total system protection

The PPF Series provides protection for the entire compressed air system. A wide range of filters exceeds customer requirements for ISO Quality Class performance, service life and optimal energy savings.

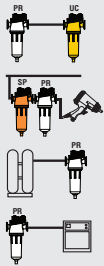
Compressed air contamination exists in three states- solid, liquid and gaseous.

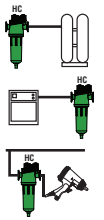
- Ingested contaminants appear in the form of water, hydrocarbons and particulates.
- The compression process introduces lubricant and wear particles into the system.
- Piping distribution and storage tanks foster contaminants in the form of rust, pipe scale and bacteria.

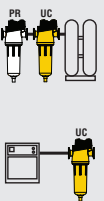
## PPF SERIES ELEMENT SPECIFICATIONS

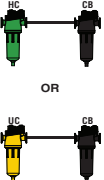
Element Grade	Description	ISO Performance Data	Where Applied
 <p><b>Grade SP Bulk Liquid Separator/Filter</b></p>	<p>Separator/filter removes bulk liquid and solids.</p>	<ul style="list-style-type: none"> <li>▪ Removes solids 3 micron and larger</li> <li>▪ Remaining oil content 5 mg/m<sup>3</sup></li> </ul> <p><b>ISO 8573.1: 2009 Air Quality Class:</b></p> <ul style="list-style-type: none"> <li>▪ Solid Particles - Class 3</li> <li>▪ Remaining Oil Content - Class 5</li> </ul>	<p>Downstream of aftercoolers</p> <p>At point-of-use if no aftercooler/ separator used upstream</p> 
 <p><b>Grade PR General Purpose Filter</b></p>	<p>General purpose filtration to protect pneumatically operated tools, motors and cylinders.</p>	<ul style="list-style-type: none"> <li>▪ Removes solids 1.0 micron and larger</li> <li>▪ Remaining oil content 2.0 mg/m<sup>3</sup></li> </ul> <p><b>ISO 8573.1: 2009 Air Quality Class:</b></p> <ul style="list-style-type: none"> <li>▪ Solid Particles - Class 2</li> <li>▪ Remaining Oil Content - Class 4</li> </ul>	<p>Upstream of ultra high efficiency oil removal filters</p> <p>At point-of-use if aftercooler/ separator installed upstream</p> <p>Downstream of heatless desiccant dryers</p> <p>Upstream of refrigerated dryers</p> 
 <p><b>Grade HC High Efficiency Oil Removal Filter</b></p>	<p>Fine coalescer provides oil free air for industrial applications such as spray painting, injection molding, instrumentation and control valves.</p>	<ul style="list-style-type: none"> <li>▪ Removes 99,999+% of solids 0.01 micron and larger</li> <li>▪ Remaining oil content &lt; 0.01 mg/m<sup>3</sup></li> </ul> <p><b>ISO 8573.1: 2009 Air Quality Class:</b></p> <ul style="list-style-type: none"> <li>▪ Solid Particles - Class 1</li> <li>▪ Remaining Oil Content - Class 1</li> </ul>	<p>Upstream of desiccant dryers</p> <p>Downstream of refrigerated dryers</p> <p>At point-of-use if aftercooler/ separator installed upstream</p> 
 <p><b>Grade UC Ultra High Efficiency Oil Removal Filter</b></p>	<p>Ultra fine coalescer delivers oil free air for critical applications including, conveying, electronics manufacturing and nitrogen replacement.</p>	<ul style="list-style-type: none"> <li>▪ Removes 99,999+% of solids 0.01 micron and larger</li> <li>▪ Remaining oil content &lt; 0.001 mg/m<sup>3</sup></li> </ul> <p><b>ISO 8573.1: 2009 Air Quality Class:</b></p> <ul style="list-style-type: none"> <li>▪ Solid Particles - Class 1</li> <li>▪ Remaining Oil content - Class 1</li> </ul>	<p>Upstream of desiccant dryers</p> <p>Upstream of membrane dryers (Use a PF Grade as a prefilter if heavy liquid loads are present)</p> <p>Downstream of refrigerated dryers</p> 
 <p><b>Grade CB Oil Vapor Removal Filter</b></p>	<p>Activated carbon filter removes oil vapor and provides oil free air for food and drug manufacturing, breathing air and gas processing.</p>	<ul style="list-style-type: none"> <li>▪ Removes solids 0.01 micron and larger</li> <li>▪ Remaining oil content &lt; 0.004 mg/m<sup>3</sup> (as a vapor)</li> </ul> <p><b>ISO 8573.1: 2009 Air Quality Class:</b></p> <ul style="list-style-type: none"> <li>▪ Solid Particles - Class 1</li> <li>▪ Remaining Oil Content - Class 1</li> </ul>	<p>Downstream of high efficiency oil removal filters</p> 



# Accessories & Options

The PPF Series is supported by a complete line of accessories and options making filter installation and differential pressure monitoring easy.

## Installation Flexibility

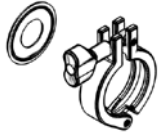

### Filter Connector Clamps

Stainless steel clamps easily connects filters in series

Optional (0020-1500)

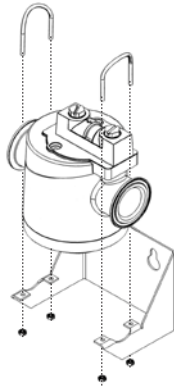

### Wall Mount Bracket

Rugged design provides installation flexibility

Optional (0020-1500)

## Pressure Monitoring

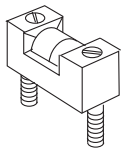

P1

### Differential Pressure Slide Indicator

Color indicator moves based on differential pressure

Standard SP, PR, UC, HC Grades (0020-1500)

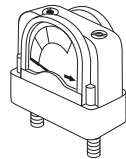

G1

### Differential Pressure Gauge

Two color gauge face indicates element change-out based on differential pressure

Standard SP, PR, UC, HC Grades (0020-1500)

## Condensate Management

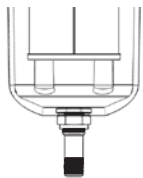

T

### Manual Drain

Condensate may be drained manually through clockwise adjustment

Standard CB Grade (0020-0401)  
Optional SP, PR, UC, HC Grades (0020-0401)

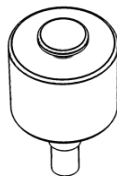

D

### No Air Loss Internal Float Drain

Effectively removes condensate without loss of air

Standard SP, PR, UC, HC Grades (0020-0401)  
Optional CB Grade (0020-0401)

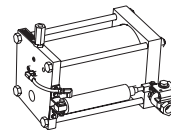

W

### No Loss Drain

Reliably removes condensate without need for electricity

Optional (0020-1500)

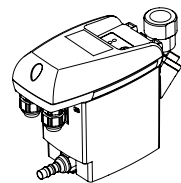

Z1

Z2

### No Air Loss Electric Demand Drain

Efficiently removes condensate based on demand

Optional (0020-1500)

# PPF Series Filter Model Number Configuration



## Housing-Connection-Flow

Model*	Connection		Flow @ 101.5 psig scfm	Flow @ 7 bar nm <sup>3</sup> /h
	in	mm		
0020	1/4"	6.4	20	34
0035	3/8"	9.5	35	59
0050	1/2"	12.7	50	85
0075	3/4"	19.1	75	127
0103	3/4"	19.1	103	175
0157	1.0"	25.4	157	267
0257	1.5"	38.1	257	437
0360	1.5"	38.1	360	612
0401	2.0"	50.8	401	681
0568	2.5"	63.5	568	993
0775	2.5"	63.5	775	1317
1030	2.5"	63.5	1030	1750
1200	3.0"	76.2	1200	2039
1500	3.0"	76.2	1500	2549

\*BSP threads are available. Add B to the model number. Example PPF-0020B-SP-DP

## Element Grade

<b>SP</b>	Bulk Liquid Removal
<b>PR</b>	Particulate Removal
<b>HC</b>	Oil Removal
<b>UC</b>	High Efficiency Oil Removal
<b>CB</b>	Oil Vapor Removal

## Options

<b>T</b>	Manual Drain
<b>D</b>	Internal Automatic Drain
<b>P1</b>	Differential Pressure Slide Indicator
<b>G1</b>	Differential Pressure Gauge
<b>X</b>	External Drain Adaptor (0020-0401)
<b>Z1</b>	Electric Demand Drain (0020-0401)
<b>Z2</b>	Electric Demand Drain (0568-1500)
<b>W</b>	External No Loss Drain (0568-1500)

### Example: PPF-0020-SP-DP1

**Flow and Connection:** 20 scfm (34 nm<sup>3</sup>/h); 1/4" NPT

**Element Grade:** SP- bulk liquid removal

**Options:** Internal automatic drain; differential pressure slide indicator

## CAPACITY CORRECTION FACTORS

PPF Series flow capacities are rated per ISO 12500 conditions @ 101.5 psig (7 bar). To size the filter for non-standard conditions, a correction factor must be applied. Table 1 provides correction factors for inlet air pressure.

*Do not select filters by pipe size; use flow rate and operating pressure.*

Table 1 - Correction Factors for Inlet Pressure

Inlet Pressure	psi	20	30	40	60	80	100	120	150	200	250	300
		bar	1.4	2.1	2.8	4.2	5.6	6.9	8.4	10.6	14.1	17.6
<b>Correction Factor</b>		0.30	0.39	0.48	0.65	0.82	1.00	1.17	1.43	1.87	2.31	2.74

## Adjusted Flow Capacity

To calculate the flow capacity based on non-standard inlet conditions, multiply the filter's rated flow capacity by the corresponding inlet pressure correction factor.

High Efficiency Coalescing Filter: PPF-0050-HC-DP

Rated capacity: 50 scfm (85 nm<sup>3</sup>/h)

Operating Conditions: 120 psig (8.3 bar)

Adjusted Flow Capacity: 50 scfm x 1.17 = 59 scfm (100 nm<sup>3</sup>/h)

## Technical Specifications

Drain Option	Maximum Operating Pressure	Maximum Operating Temperature	Minimum Operating Temperature
Manual Drain	250 (17 bar)	150°F (65°C)	35°F (2°C)
Internal Float	250 (17 bar)	150°F (65°C)	35°F (2°C)
Electric Demand	232 (16 bar)	140°F (60°C)	35°F (2°C)
Externally No Loss	130 (9 bar)	180°F (82°C)	35°F (2°C)

CB Grade: Recommended maximum inlet air temperature not to exceed 100°F to maintain 1,000 hours of life

# PPF Series Specifications

Model Number	Max. Flow @ 101.5 psig (7 bar)		Connections NPT	Dimensions								Weight	
	scfm	nm <sup>3</sup> /h		"A"		"B"		"C"		"D"		lbs	kg
				in	mm	in	mm	in	mm	in	mm		
PPF-0020	20	34	1/4"	4.5	114	8.1	206	6.8	173	4	102	1.8	0.8
PPF-0035	35	59	3/8"	4.5	114	8.1	206	6.8	173	4	102	1.8	0.8
PPF-0050	50	85	1/2"	4.5	114	9.9	251	8.5	216	4	102	1.9	0.9
PPF-0075	75	127	3/4"	5.2	132	10.3	262	8.7	221	5	127	3.1	1.4
PPF-0103	103	175	3/4"	5.2	132	10.3	262	8.7	221	5	127	3.1	1.4
PPF-0157	157	267	1"	5.2	132	12.8	325	11.7	297	5	127	3.5	1.6
PPF-0257	257	437	1.5"	7.9	201	13.3	338	10.9	277	7	178	8.4	3.8
PPF-0360	360	612	1.5"	7.9	201	17.1	434	14.7	373	7	178	9.9	4.5
PPF-0401	401	681	2"	7.9	201	22.3	566	19.9	505	7	178	11.6	5.3
PPF-0568	568	993	2.5"	9.1	231	24.9	632	21.7	551	8	203	18.6	8.5
PPF-0775	775	1317	2.5"	9.1	231	24.9	632	21.7	551	8	203	18.6	8.5
PPF-1030	1030	2039	3"	9.1	231	32.2	818	28.9	734	8	203	27.7	12.6
PPF-1200	1200	2039	3"	9.1	231	32.2	818	28.9	734	8	203	27.7	12.6
PPF-1500	1500	2549	3"	9.1	231	42.7	1085	39.4	1001	8	203	41.3	18.8

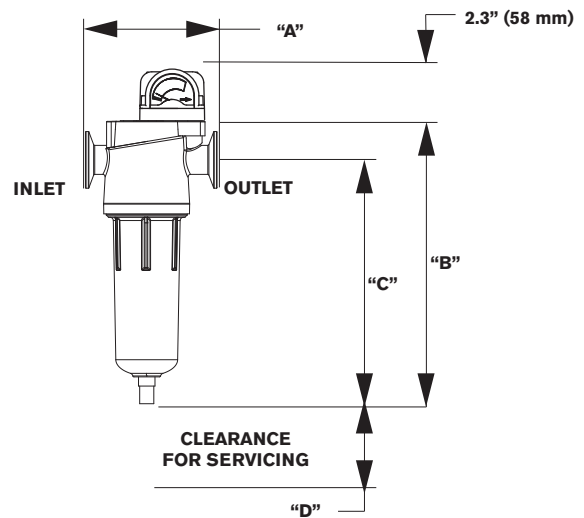
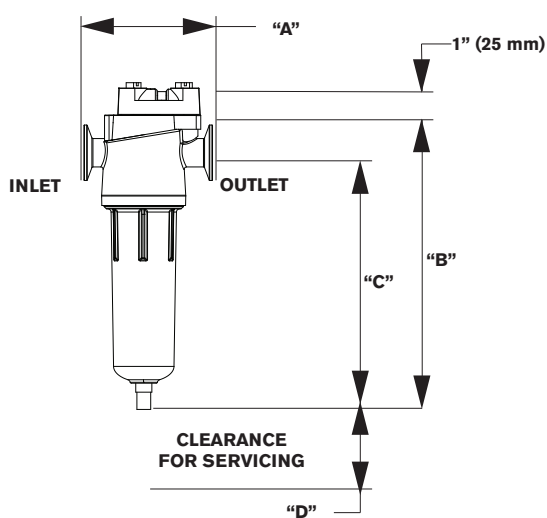

# Advanced Energy Saving Compressed Air Filters

PPF SERIES



## Global locations

### USA

#### SPX FLOW TECHNOLOGY

4647 SW 40th Avenue  
Ocala, Florida 34474-5788  
United States of America  
P: (352) 873-5793

### APAC

#### SPX ASIA PACIFIC

2F, Treasury Building  
1568 Hua Shan Road  
Shanghai 20000523  
Peoples Republic of China  
P: +86 21 2208 5888

### EMEA

#### SPX FLOW TECHNOLOGY ETTEN-LEUR BV

Munnikenheiweg 41  
4879NE Etten-Leur  
The Netherlands  
P: +31 (0)76 5085545

#### SPX FLOW TECHNOLOGY

4647 SW 40th Avenue  
Ocala, Florida 34474-5788 U.S.A.  
P: (352) 873-5793  
F: (352) 873-5770  
E: [ppc.americas@spx.com](mailto:ppc.americas@spx.com)  
[www.spx.com/pneumatic-products](http://www.spx.com/pneumatic-products)

SPX reserves the right to incorporate our latest design and material changes without notice or obligation.

Design features, materials of construction and dimensional data, as described in this bulletin, are provided for your information only and should not be relied upon unless confirmed in writing. Please contact your local sales representative for product availability in your region. For more information visit [www.spx.com](http://www.spx.com).

The green ">" is a trademark of SPX Corporation, Inc.

ISSUED 07/2013 PPF\_US

COPYRIGHT © 2013 SPX Corporation