

Type T Fabricated Construction



- Custom Sizes
- Carbon Steel or Stainless Steel

FEATURES

- Fabricated Construction
- High Efficiency Over Wide Flow Range
- No Required Maintenance
- Economical Choice for Most Applications
- Removes 99% of Liquid and Solid Entrainment Particles Larger Than 10 Microns
- Gas, Steam, or Air Applications

OPTIONS

- ASME UM or U Code Stamp
- Hundreds of Design Options to Conform to Application Requirements
- Support Legs



High Efficiency – No Maintenance

The Eaton Type T Gas/Liquid Separator automatically removes 99% of all liquid and solid entrainment particles 10 microns in size or larger from air, gas, and steam processes. And it does so with no moving parts to wear out and with no required maintenance. The Type T, with its cost-effective design, is the separator of choice for most applications that require clean, dry air, gas or steam.

Exclusive Design

Moisture-laden gas enters the inlet of the separator where it is deflected in a centrifugal downward motion. The entrained solids and moisture droplets are separated out by a reduction in velocity. Separated liquid and solids fall into a reservoir where the exclusive Eaton Vortex Containment Plate (VCP) ensures that they cannot be re-entrained. The clean, dry flow is then directed to the outlet by the VCP. This eliminates the need for expensive, delicate baffles used in ordinary separators.

Application Flexibility

Fabricated separators are manufactured one at a time and are made to fit the exact requirements of unusual applications with unique size or piping connections. They are lighter in weight than a comparable size cast separator. There are no trade-offs with a fabricated separator. You get the perfect unit for your application. You never have to pay for more separator than you need, or settle for a separator that won't quite do the job you want it to.

Fabricated Construction

Fabricated Type T Gas/Liquid Separators are available in sizes from 1" to 24" in carbon steel or stainless steel construction. Fabricated construction separators are built to order and can be easily manufactured to exactly meet the requirements of special applications or applications where weight is a concern.



Powering Business Worldwide

Type T Fabricated Gas/Liquid Separators

Dimensions: Type T (Carbon Steel & Stainless Steel) - Threaded, Socket Weld & Flanged (in/mm)

Pipe Size	Threaded & Skt Weld A	Flanged 150 lb & 300 lb A	Flanged 600 lb A	B	Cast C	Fab C	D	G	NPT Drain Std	NPT Drain Opt'l	-----Weight (lb/kg)-----			
											Tht'd & Skt Weld 1000 psig @ 650 °F	Flanged 150 psig @ 450 °F	Flanged 500 psig @ 650 °F	Flanged 750 psig @ 650 °F
1	6.37 / 162	10.5 / 267	12 / 305	10.5 / 267	12 / 305	16 / 406	5.56 / 141	4.75 / 121	1	1-1/2	29 / 13	33 / 15	35 / 16	37 / 17
1-1/4	6.37 / 162	10.5 / 267	12 / 305	10.5 / 267	12 / 305	16 / 406	5.56 / 141	4.75 / 121	1	1-1/2	30 / 14	35 / 16	37 / 17	42 / 19
1-1/2	7.62 / 194	11.5 / 292	14 / 356	12.5 / 317	14 / 356	19 / 483	6.62 / 168	4.75 / 121	1	2	55 / 25	50 / 23	56 / 25	59 / 27
2	7.87 / 200	11.5 / 292	14 / 356	12.5 / 317	14 / 356	19 / 483	6.62 / 168	4.75 / 121	1	2	57 / 26	55 / 25	59 / 27	54 / 25
2-1/2	-	16 / 406	18 / 457	15 / 381	-	22 / 559	8.62 / 219	5.75 / 146	1	2	-	100 / 45	110 / 50	125 / 57
3	-	18 / 457	20 / 508	18 / 457	-	26 / 660	10.75 / 273	5.75 / 146	1-1/2	2-1/2	-	140 / 64	150 / 68	175 / 80
4	-	20 / 508	22 / 559	22 / 559	-	31 / 787	12.75 / 324	5.75 / 146	1-1/2	2-1/2	-	195 / 89	220 / 100	295 / 134
5	-	22 / 559	24 / 610	26 / 660	-	36 / 914	14 / 356	7.87 / 200	1-1/2	2-1/2	-	230 / 105	290 / 132	435 / 198
6	-	24 / 610	28 / 711	30 / 762	-	41 / 1041	16 / 406	7.87 / 200	1-1/2	2-1/2	-	350 / 159	380 / 173	715 / 325
8	-	28 / 711	32 / 813	37 / 940	-	50 / 1270	18 / 457	7.87 / 200	2	3	-	475 / 216	610 / 277	1070 / 486
10	-	34 / 864	38 / 965	55 / 1397	-	70 / 1778	24 / 610	7.87 / 200	2	3	-	780 / 355	1180 / 536	2065 / 939
12	-	38 / 965	42 / 1067	58 / 1473	-	75 / 1905	28 / 711	7.87 / 200	1-1/2	4*	-	940 / 427	1510 / 686	2750 / 1250
14	-	42 / 1067	46 / 1169	60 / 1524	-	79 / 2007	32 / 813	7.87 / 200	2-1/2	4*	-	1155 / 525	2205 / 1002	3400 / 1545
16	-	47 / 1194	51 / 1295	68 / 1727	-	89 / 2261	36 / 914	7.87 / 200	3	5*	-	1605 / 730	2785 / 1266	4750 / 2159
18	-	54 / 1372	58 / 1473	85 / 2159	-	109 / 2769	42 / 1067	9.12 / 232	3	5*	-	2260 / 1027	4370 / 1986	6295 / 2861
20	-	62 / 1575	66 / 1676	99 / 2515	-	126 / 3200	48 / 1219	9.12 / 232	3	5*	-	2845 / 1293	5635 / 2561	8600 / 3909
22	-	64 / 1626	68 / 1727	102 / 2591	-	130 / 3302	48 / 1219	10.25 / 260	3	5*	-	3000 / 1364	6085 / 2766	10900 / 4955
24	-	70 / 1778	74 / 1880	109 / 2769	-	140 / 3556	54 / 1372	10.25 / 260	4*	6*	-	4295 / 1952	7845 / 3566	14000 / 6364

* Flanged drain

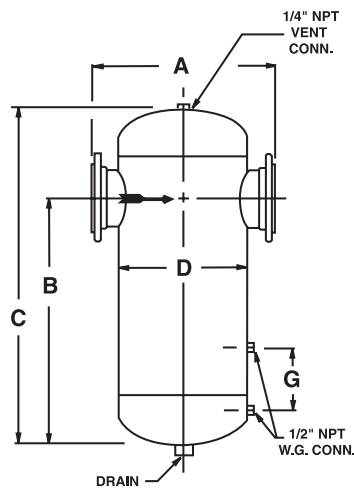
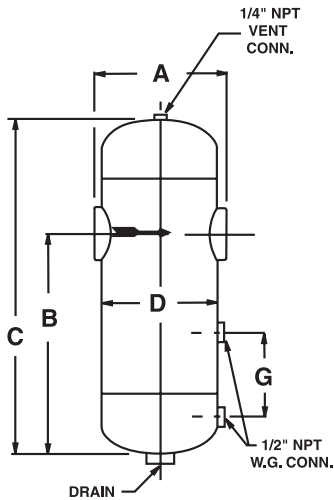

North America – HQ

70 Wood Avenue, South
2nd Floor
Iselin, NJ 08830

Toll Free: (800) 656-3344
(North America only)

Voice: (732) 767-4200

Brazil

Voice: +55 (11) 2465-8822

China

Voice: +86-21-5200-0099

Europe/Africa/Middle East

Voice: +49-2486-809-0

Singapore

Voice: +65-6825-1668

©2012 Eaton Corporation. All Rights Reserved. All trademarks and registered trademarks are the property of their respective owners. Litho USA. All information and recommendations appearing in this brochure concerning the use of products described herein are based on tests believed to be reliable. However, it is the user's responsibility to determine the suitability for his own use of such products. Since the actual use by others is beyond our control, no guarantee, expressed or implied, is made by Eaton as to the effects of such use or the results to be obtained. Eaton assumes no liability arising out of the use by others of such products. Nor is the information herein to be construed as absolutely complete, since additional information may be necessary or desirable when particular or exceptional conditions or circumstances exist or because of applicable laws or government regulations.

For more information, e-mail us at filtration@eaton.com, or call 732-767-4200.

Visit us online at eaton.com/filtration for a complete list of Eaton's filtration products.



Powering Business Worldwide



EF-G/L-3
6-2012