



**SUNCOR'S FORT HILLS WORKERS' CAMP**  
FORT McMURRAY, ALBERTA, CANADA



4" ROLLED GROOVE  
4" ROLLED GROOVE  
6" ROLLED GROOVE  
6" ROLLED GROOVE  
3" ROLLED GROOVE

A3  
632D-2101  
FT21011

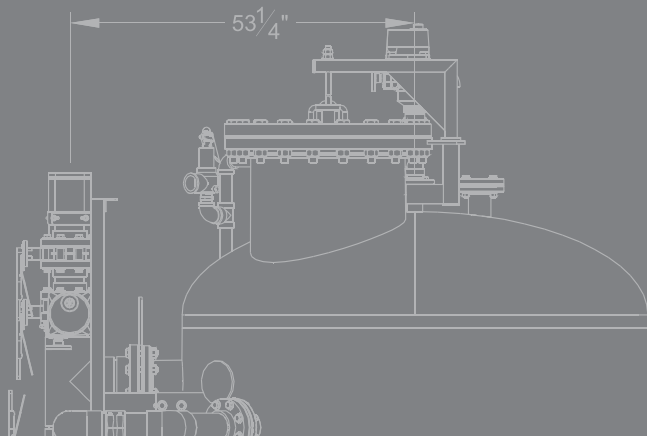

## SUNCOR'S FORT HILLS WORKERS' CAMP

FORT McMURRAY, ALBERTA, CANADA

**- MARKET -**  
Energy – Oil & Gas

**- APPLICATION -**  
Drinking & Utility Water

**- WATER SOURCE -**  
Surface Water

**- TECHNOLOGIES -**  
Media Filters  
+ UF (Ultrafiltration)  
+ RO (Reverse Osmosis)  
+ UV (Ultraviolet)

**- HIGHLIGHTS -**

Flow rate: 2 x 1,500 m<sup>3</sup>/d (2 x 275 gpm)

Delivery of the system, already assembled, to the far north of Alberta (56<sup>th</sup> parallel).

One pre-fabricated modular building split into 4 sections that were reconnected together once delivered on site.