

# **ALBIN PUMP ALP**

**PERISTALTIC PUMP**



# ALP PERISTALTIC RANGE LOW PRESSURE

## Reduce maintenance downtime...

Suitable for pumping and dosing low or high viscous, pasty, pure, neutral, aggressive or abrasive liquids, those containing gases or which tend to froth or those containing solids in the following industries : paint, dairy and beverage, meat and fish processing, pharmaceutical and cosmetics Waste water and water treatment engineering, chemical and petrochemical industries, pulp and paper, textile, soap and fats i, building, ceramics.

## ALBIN PUMPS provide process confidence and offer cost savings through :

- Accurate and repeatable dosing and metering
- Long life and greater reliability
- Self-priming
- Continuous dry running
- Lowest cost of ownership
- Quick and easy maintenance

### SELF-PRIMING and dry-running

It is not always possible to position a pump in the ideal location and often self-priming and dry-running performance is required. These conditions can cause wear in conventional pumps, resulting in loss of flow and premature failure. ALBIN PUMP can self-prime up to 9.8 metres and run dry indefinitely.

### LOWEST COST of ownership with quick and easy maintenance

Leakage, clogging or blockage of conventional positive displacement pumps which incorporate seals, valves, lobes, rotors or vanes can be a regular occurrence and expensive to rectify. ALBIN PUMPS contain the fluid in a tube or hose, requiring only one component to be changed, which means that maintenance costs are considerably lower than other pump types. Increased plant productivity and lower repair costs means pump payback is over months rather than years.

### ACCURATE and REPEATABLE dosing and metering

Industry requires repeatable pump control for accurate dosing. Many traditional positive displacement pumps deliver varying flow rates, resulting in scrapped product and increased costs. ALBIN PUMPS are accurate up to  $\pm 0.5\%$  across their total speed range, with the additional benefit of process control capabilities which allows easy installation. Less waste means increased profits.

### LONG LIFE and greater reliability

Pump failure cannot be tolerated. ALBIN PUMP have no seals, valves, diaphragms, glands or immersed rotors to leak, clog or replace. Abrasive, corrosive and aggressive liquids are handled with ease because the fluid stays within the tube and never comes into contact with moving parts of the pump. The ALP range is designed and manufactured for heavy duty industrial use, and advanced elastomer technology ensures accurate and repeatable performance that truly outperforms all other pumps.

## USING A PROUVEN DESIGN

Two rollers mounted at 180° on a rotor compress alternatively a thick-walled hose in a patented concentric guide and push the pumped liquid from the suction to the discharge side. Roller movement compresses the hose along the casing wall and creates constant vacuum at the suction side of the pump. In this way, liquids are conveyed within the hose and do not get in contact with any metal part.

ALBIN PUMPS clearly outperform other pumps which rely on seals, valves or vanes for their operation. These components are repeatedly the cause of pump failure and high maintenance. No other positive displacement pump offers this unique separation of pump and fluid.

In sizes ALP 09-ALP 25, the rotor is supported by oversized ball bearings located within the pump casing; in sizes ALP 30 - ALP 45 the rotor is supported by the heavy-duty bearings of the flanged drive unit.

The ALBIN PUMP ALP range provides flow rates from micro-litres per minute to 10 cubic metres per hour and pressures up to 5 bar. Fixed, variable, flameproof, and air operated drives, with comprehensive control options to enable pumps to be configured to your requirements.

## WITH EXPERTS advice to give the best system and installation ... To deliver the PROMISED RESULTS

Our customers have made major improvements in process performance, maintenance and product quality, resulting in cost savings previously thought unavailable.

### AVAILABLE HOSES MATERIALS

- Neoprene®
- Hypalon
- NR
- NBR - foods
- Norprene®
- Silicone
- EPDM
- Pharmed®

*Other qualities on demand.*

- > Without reinforcing :  
Neoprene® ; Hypalon ; Norprene® ; Silicone ; Pharmed®
- > With polyamide reinforcing :  
Natural rubber (NR) ; NBR ; EPDM



### Operating data

Capacity	up to 10 m <sup>3</sup> /h
Viscosity	up to 15000 cps(3)
Temperature of pumped liquid	up to 135°C (1)
Differential pressure	up to 4 bar (2)
Discharge pressure	up to 4 bar
Achievable suction	up to 0.6 bar (3)

1- At a room temperature of 20°C. Furthermore, it depends on the pumped fluid, on the hose quality and on the motor construction.

2- It depends on the pump dimension and on the hose quality.

3- It depends on the pump dimension/execution, on the speed and on the tube material.

## ALBIN PUMP PERISTALTIC IN YOUR INDUSTRY

**Albin pumps are exceptionally low shear, ensuring product quality, accurate and predictable performance with subsequent cost savings.**

### Pharmaceutical industry

**Challenge :** it demand sterility and a high degree of precision to ensure the integrity and quality of the end product. Fluid isolation and precise metering are vital, and not meeting these demands can be enormously costly.

**Pumped fluids :** chemical dosing, liquid protein, vaccines, serum, plasma, syrups.

### Water treatment

**Challenge :** reduce the down time due to maintenance of costly dosing pumps and elimination of expensive auxiliary equipment.

**Pumped fluids :** sodium hypochlorite, ferric chloride, sodium bisulfite, fluoride, polymers, aqueous ammonia, potassium permanganate, caustic soda, and many more.

### Pasta industry

**Challenge :** inspectors are concerned about contamination if the hose breaks. Our competition uses a food grade oil for hose lubrication, but within 1-2 days the hose begins to wear (turns black), requiring the customer to change hoses every 2 days.

**Pumped fluids :** egg white & yolk, edible fat, semolina, natural flavoring.

### Bread dough & fruit cake manufacturers

**Challenge :** require semi-accurate metering of viscous products containing solids.

**Pumped fluids :** water & salt mixtures, natural flavorings, fats, fruit cake dough/mixture (i.e. fruit cake has nuts and fruit pieces that need to stay whole).

### Cheese manufacturers

**Challenge :** require a low shear pump so fibers in cheese aren't separated.

**Pumped fluids :** Cream, milk and yogurt.

### Shampoo manufacturers

**Challenge :** eliminate potential for foaming fluid on bottle filling lines. Harsh pumping action of air operated diaphragm pumps can cause the fluid to foam.

**Pumped fluids :** shampoos

## ALP TUBING

**ALBIN PUMP SAS have selected the most comprehensive range of tubing to suit all the specific need of the industry.**

MATERIAL	Hose Identification	Operating Temperatures	Industry Approvals	Available
Neoprene	Flat black color, rough surface, rubber smell	0 to 60°C		ALP09 to ALP25
Norprene®	Off white, smooth surface	-35 to 135°C	USP Class VI	ALP09 to ALP45
			FDA 21	
			CFR 177.2600	
			NSF listed (Standard 51)	
Silicone	Transparant, smooth surface	0 to 140°C	USP Class VI	ALP09 to ALP25
			FDA 21	
			CFR177.2600	
Pharmed®	Cream color, Pharmed* name on hose	-30 to 135°C	USP Class VI	ALP09 to ALP13
			FDA 21	
			CFR 177.2600	
			NSF listed (Standard 51)	
Hypalon	Black color, yellow stripe, double braided	0 to 90°C		ALP09 to ALP45
EPDM Rubber	Black color, white stripe, double braided	0 to 90°C		
Natural Rubber	Black color, green stripe, double braided	0 to 80°C		
Nitrile Rubber	Black color	0 to 80°C		

## HOSES DIMENSIONS

SIZE	ID	OD	Length
	mm		
ALP 09	9	16	330
ALP 13	13	22	390
ALP 17	17	31	590
ALP 25	25	43	860
ALP 30	30	55	1150
ALP 45	45	75	1455



© Pharmed Reg. Saint-Gobain Performance Plastics

**MOTORIZATION**

**Gear motors or variable speed motors, both TEFC and flame-proof, electronic gear motor, inverters. Upon request, pneumatic drive units are available.**

## CONSTRUCTION

REF	DESCRIPTION	MATERIAL DESIGN
1	Pump casing	Aluminium alloy
2	Rotor	Aluminium alloy
3	Pressure rollers	Plastic/light alloy (1)
4	Pump hose	(2) See hose material chart page 4.

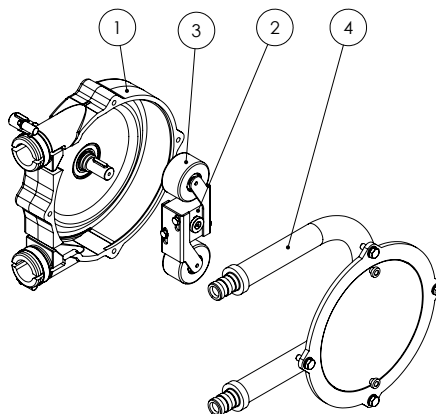

ALP30 & 45  
shim roller  
adjustment.

(1) According to pump size  
(2) According to pumped liquid and to operating conditions

SIZE	A	B	C	D	E	F	G	H	I	J	K	L	M	N	O	P	ØQ
ALP 09F	114	75	104	58	185	110	145	160	156	170	3,5	25	20	187,5	15	335	6
ALP 09VM	114	75	104	58	185	110	145	160	156	170	3,5	25	20	187,5	15	485	6
ALP 13F	126	95	132	61	222	127	165	180	156	170	10	28	20	197	19	352	6
ALP 13VM	126	95	132	61	222	127	165	180	156	170	10	28	20	197	19	502	6
ALP 17F	187	131	188	73	290	167	220	235	180	200	13,5	40,5	35	235,5	25	427	6
ALP 17VM	187	131	188	73	290	167	220	235	180	200	13,5	40,5	35	235,5	25	527	6

**F = Fixed Speed Geared Motor Only**  
**VM = Mechanical Variator & Geared Motor**

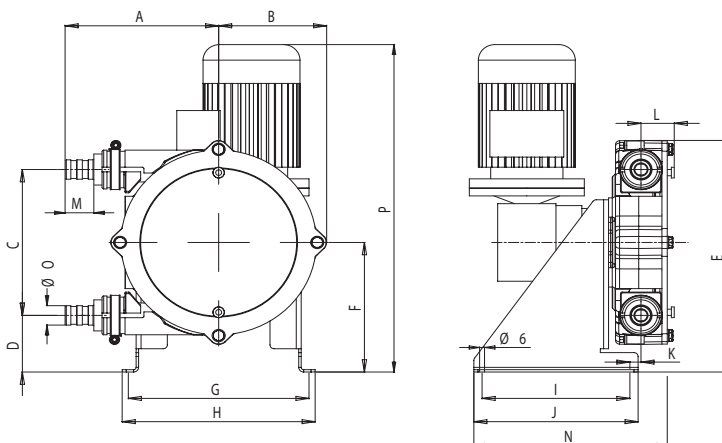

SIZE	A	B	C	D	E	F	G	H	I	J	K	L	M	N	O	P	ØQ
ALP 25F	275	170	256	90	388	218	240	270	400	440	18	52,5	45	482	38	580	11
ALP 25VM	275	170	256	90	388	218	240	270	400	440	18	52,5	45	482	38	720	11
ALP 30F	345	226	364	148	556	330	330	380	550	600	22	66,5	55	655,5	45	672,5	14
ALP 30VM	345	226	364	148	556	330	330	380	550	600	22	66,5	55	655,5	45	812,5	14
ALP 45F	455	287	456	157	672	385	420	470	650	700	40	79	70	786	60	776,5	14
ALP 45VM	455	287	456	157	672	385	420	470	650	700	40	79	70	786	60	916,5	14

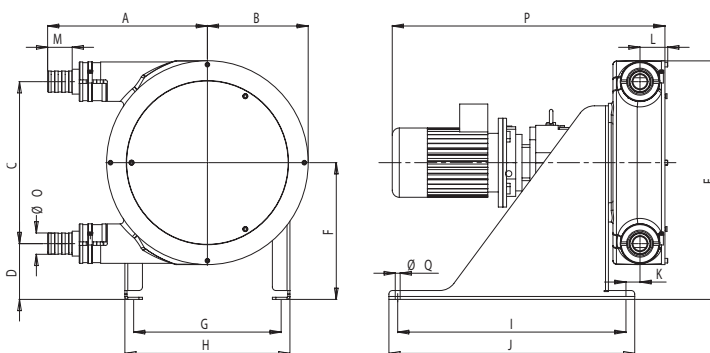

A large, stylized graphic of green leaves or blades of grass, rendered in various shades of green, curves across the right side of the page from the top right towards the bottom right.

**ALBIN PUMP SAS**

ZAC de Fontgrave  
26740 Montboucher sur Jabron  
France

Tel +33 (0) 4 75 90 92 92

Fax +33 (0) 4 75 90 92 40

info@albinpump.fr

www.albinpump.fr

For more information about our worldwide locations, approvals, certifications, and local representatives, please visit [www.albinpump.com](http://www.albinpump.com).

ALBIN PUMP reserves the right to incorporate our latest design and material changes without notice or obligation.

Design features, materials of construction and dimensional data, as described in this bulletin, are provided for your information only and should not be relied upon unless confirmed in writing.

Certified drawings are available upon request. © 2008 ALBIN PUMP