

8 x 40 EXTRA-FLOW PRODUCT DATA SHEET

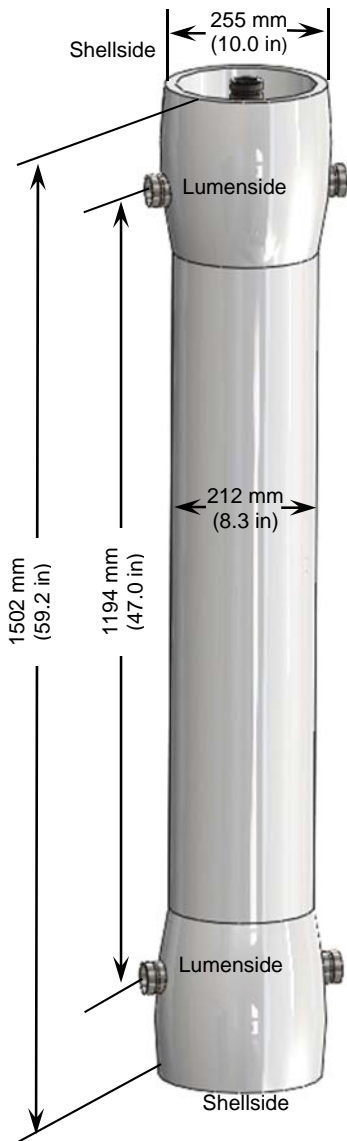

NOTE: All dimensions are nominal values.

Membrane Characteristics	
Cartridge Configuration	Extra-Flow with Center Baffle
Liquid Flow Guidelines	7 – 28 m ³ /hr (30 – 125 gpm)
Membrane Type	X40 Fiber
	Recommended for high pressure O ₂ removal and other gas transfer applications
Membrane/Potting Material	Polypropylene / Epoxy
Typical Membrane Surface Area	121 m ² (1302 ft ²)
Priming Volume	
Shellside	15.4 L (4.1 gal)
Lumenside	13.6 L (3.6 gal)
Pressure Guidelines*	
Maximum Shellside <u>LIQUID</u> Working Temperature/ Pressure	5-25° C, 19.7 barg (41-86° F, 285 psig) 60° C, 12.0 barg (140° F, 175 psig) 85° C, 1 barg (185° F, 15 psig)
If no vacuum is used, 1 barg (15 psig) can be added to pressures above.	
Maximum Applied Gas Pressure	2.1 barg at 25° C (30 psig at 77° F)
Max applied gas pressure is for integrity testing at ambient temperatures. Normal operating pressures are typically lower.	
* See Operating Guide for complete listing of temp/pressure limits for housings and membrane. Note: Liquid pressure should always exceed gas pressure.	
Housing Options and Characteristics	
Material	Fiber Reinforced Plastic (FRP) FRP Vessel Code-rated to ASME BPVC Section X
Connections	
Shellside (Liquid Inlet/Outlet)	• 1.5 Inch Grooved pipe fitting
Lumenside	• 1.5 Inch Grooved pipe fitting
Seal Options	
Material	Applications
EPDM	All Purpose
Weight (approximate)	
Dry	35 kg (78 lbs)
Liquid Full (shellside)	50 kg (110 lbs)
Shipping Weight	Additional 3-6 kg (6-12 lbs). Does not include pallet weight.

8 x 40 EXTRA-FLOW PRODUCT DATA SHEET

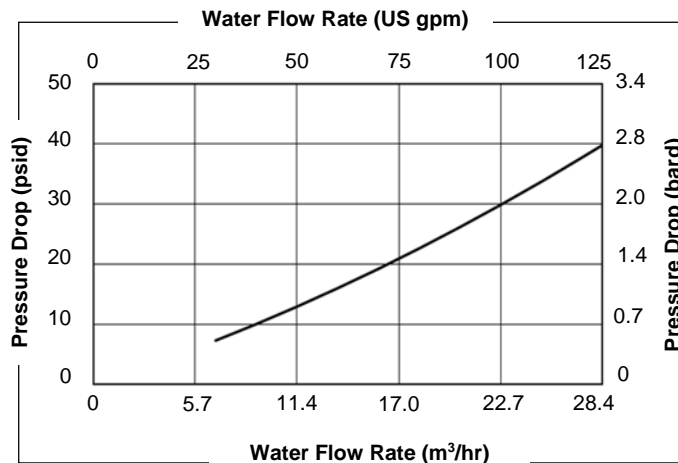
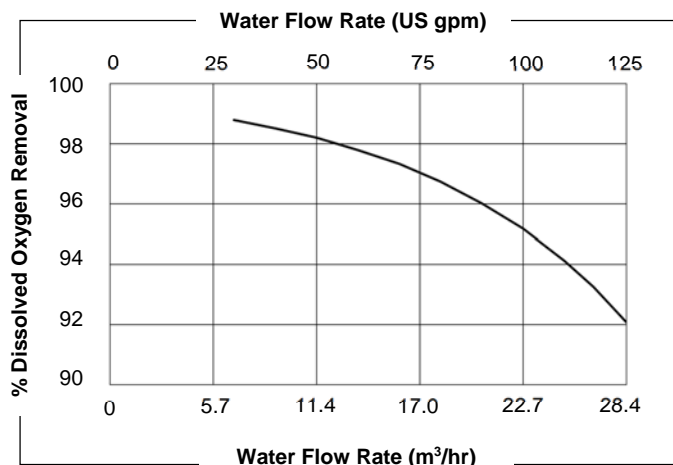

Curves represent nominal values with FRP housing using water at 20° C. Characteristics may change under different operating conditions.

Test condition O₂ Removal with X40 membrane: N₂-vacuum combo mode, vacuum: 50 mm Hg N₂ sweep: 0.5 SCFM.

Technical Information: The technical information, recommendations and other statements contained in this document are based upon tests or experience that 3M believes are reliable, but the accuracy or completeness of such information is not guaranteed.

Product Use: Many factors beyond 3M's control and uniquely within user's knowledge and control can affect the use and performance of a 3M product in a particular application. Given the variety of factors that can affect the use and performance of a 3M product, user is solely responsible for evaluating the 3M product and determining whether it is fit for a particular purpose and suitable for user's method of application.

Warranty, Limited Remedy, and Disclaimer: Unless an additional warranty is specifically stated on the applicable 3M product packaging or product literature, 3M warrants that each 3M product meets the applicable 3M product specification at the time 3M ships the product. 3M MAKES NO OTHER WARRANTIES OR CONDITIONS, EXPRESS OR IMPLIED, INCLUDING, BUT NOT LIMITED TO, ANY IMPLIED WARRANTY OR CONDITION OF MERCHANTABILITY OR FITNESS FOR A PARTICULAR PURPOSE OR ANY IMPLIED WARRANTY OR CONDITION ARISING OUT OF A COURSE OF DEALING, CUSTOM OR USAGE OF TRADE. If the 3M product does not conform to this warranty, then the sole and exclusive remedy is, at 3M's option, replacement of the 3M product or refund of the purchase price.

Limitation of Liability: Except where prohibited by law, 3M will not be liable for any loss or damage arising from the 3M product, whether direct, indirect, special, incidental or consequential, regardless of the legal theory asserted, including warranty, contract, negligence or strict liability.

3M, Membrana and Liqui-Cel are trademarks of 3M Company.
© 2015 3M Company. All rights reserved. (D108 Rev11)



**Industrial Business Group
Membranes Business Unit**
13840 South Lakes Drive
Charlotte, North Carolina 28273
USA

Phone: +1 704 587 8888
Fax: +1 704 587 8610

**3M Deutschland GmbH
Membranes Business Unit**
Öhder Straße 28
42289 Wuppertal
Germany

Phone: +49 202 6099 - 658
Fax: +49 202 6099 - 750

**3M Japan Ltd.
Membranes Business Unit**
6-7-29, Kita-Shinagawa,
Shinagawa-ku, Tokyo | 141-8684
Japan

Phone: +81 3 6409 5732
Fax: +81 3 6409 5827



www.liqui-cel.com