



## AUTHORIZED CANADIAN DISTRIBUTOR



**SPRAYING  
PUMPING  
FILTERING  
AND VALVES**

**JOHN BROOKS COMPANY LIMITED**

1-800-624-5757 | [www.johnbrooks.ca](http://www.johnbrooks.ca)

### PRIMARY TREATMENT

VERTICAL TUBE COALESCING SEPARATOR (VTC)

0-500 GPM IN A SINGLE STRUCTURE

600 GPM AND GREATER REQUIRE MULTIPLE STRUCTURES

### FUNCTION

REMOVES FREE OILS

NON-PERMANENT MECHANICALLY EMULSIFIED OILS

SETTLABLE SOLIDS



ENGINEERING A BETTER ENVIRONMENT

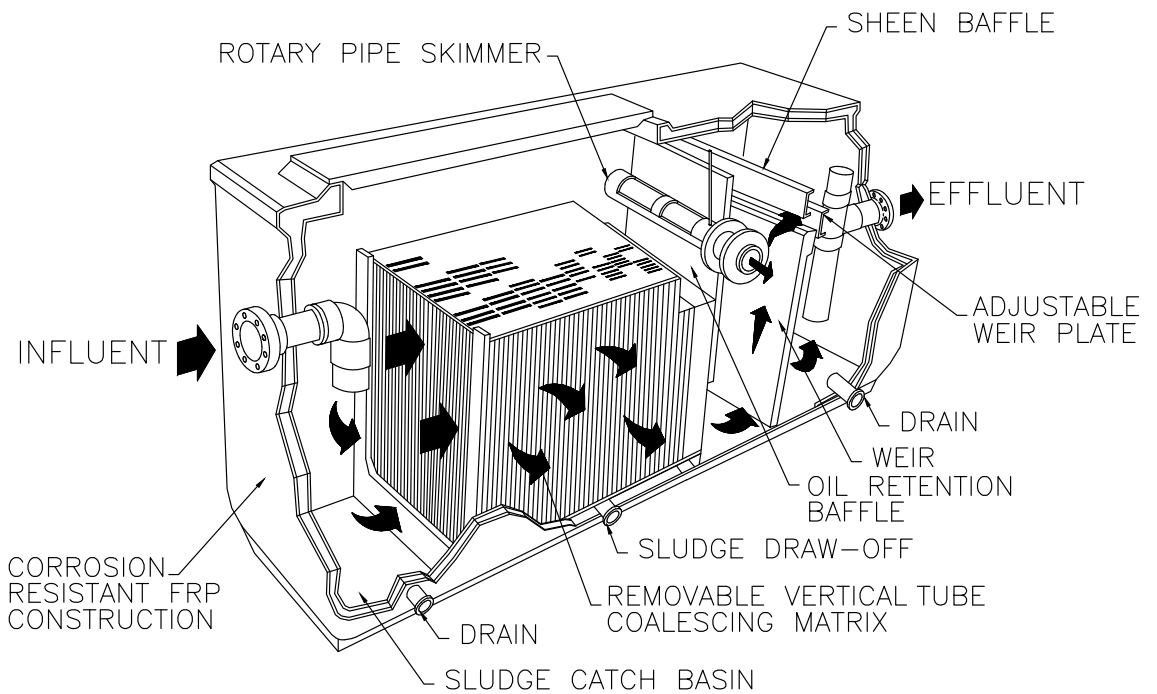

## FEATURES

**More efficient separation**

**Flow rates: 5-2,500 GPM**

**Low heat transfer, less than 1.0 U factor**

**Corrosion-resistant throughout**

**Pre-engineered, prepackaged, ready to install**

**Self contained, no power source required**

**Built-in oil storage (optional)**

The VTC removes hydrocarbons and settleable solids from industrial wastewater and coolant. In operation, this separator accepts industrial liquid waste in the inlet chamber. Here settleable solids fall to the bottom as sludge for periodic removal.

Then the waste stream enters the coalescing separation chamber. A matrix of vertically-positioned polypropylene tubes gives laminar flow characteristics to the liquid. The results is a liquid more responsive to gravity separation.

The tubes also provide a coalescing medium. Oleophilic in nature, they attract small oil globules which coalesce with other globules, increase in size and buoyancy, then break away to rise through the tubes to the top. Surface oil drains by gravity into a rotary pipe skimmer for discharge to a storage facility.



ENGINEERING A BETTER ENVIRONMENT

Performance that can be expected of the VTC separator is:

1. Removal of oil globules down to **20-micron size**
2. Reduction of oil content to **10mg/ltr/10ppm.**

The VTC removes even non-permanent mechanically emulsified oil. It leaves no visible sheen and traps the solids too. In metalworking and similar applications, it removes more than 99 percent of tramp oils from coolants.

The VTC incorporates a molded fiberglass construction. Internally reinforced, the structure withstands severe soil and hydraulic loadings.

The entire surface is covered with corrosion-resistant gel coat, integrally-colored and ultra-violet resistant. Since the envelope and fittings are corrosion-resistant, the separator can be installed in many hostile environments. No sacrificial cathodic protection is required.

Equipment and construction options are available. These include heater packages, sludge removal provisions, effluent pump-out systems, built -in oil storage tank, oil stop valve and special resins or stainless steel construction.

## VTC Options

Ladders and Hand Rails  
Height Extension  
Internal Oil Storage  
Separate Oil Storage  
Manifolding In and Out  
Oil Stop Valve Installed

Stainless Steel Construction  
Special Resins  
FRP Piping  
CPVC Piping  
Delta Packs

Freeze Protection - Elect  
Influent Pumps Air and Elect  
Effluent Pumps Air and Elect  
Sludge Pumps Air and Elect  
Level Switch Oil and Water  
Nema 4x and Nema 7 Packages  
Floating Skimmers - Air Only

## TUBES REMOVE OIL

VERTICAL TUBE COALESCING  
PRINCIPLE OF OPERATION

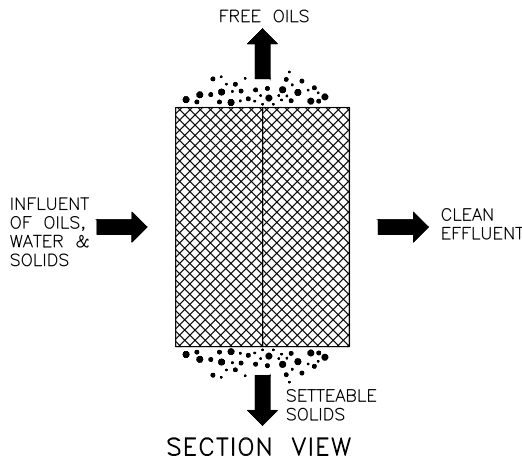

At the heart of the AFL Industries separator is a unique vertical-tube coalescer. Tubes reduce free oil content of effluent down to **10 mg/ltr/10ppm**, or less. The growing oil globules, when sufficiently buoyant, break free to rise to the surface. The random tube matrix provides laminar flow essential for proper separation. Small oil droplets are attached to the virgin-polypropylene tube matrix because of its oil -attracting characteristics. Once attached, they provide additional surface area to the tubes while attracting other small oil droplets with their own inherent properties. This process combines oil droplets until they are large enough to rise to the surface to await periodic removal. The coalescer is lightweight and removable for maintenance.