

The JET-1™ is ideal for air knife drying, vacuum, fluidized bed, cooling and exhaust applications. The JET-1™ is the most compact centrifugal blower available and features belt-free DirectDrive™ Technology (US & Int'l. Pat. Pend.), which is enabled by a proprietary high-speed motor and an aerodynamically designed blower. DirectDrive™ enhances reliability and boosts performance by eliminating belts, tensioning devices and complex spindle assemblies common in other high-speed blowers. The JET-1™ is engineered for moderate flow and moderate pressure applications from 5HP [3.7kW] to 10HP[7.5kW]. Its design and compact footprint enable it to fit into the widest range of OEM equipment.

JET-1™



Advantages:

- **Efficient Power:** The JET-1™ is 10-12% more efficient than belt drive units. Available in 5-10HP or [3.7-7.5kW] ratings.
 - Flow: 760cfm [1280M3Hr]
 - Pressure: 65"WG [160mBar]
 - Vacuum: 58"WG [145mBar]
- **Ultra Compact:** Smallest footprint. One man install. Fed-Ex, DHL, and UPS delivery available. (See dimensions below.)
- **More Reliable:** Built-in motor protection. Ultra-balanced motor shaft. 1 year warranty and fewer parts.
- **Better ROI:** Most efficient energy use. No belts or adjustment costs. Lowest delivery costs.
- **Smart Control:** Variable Frequency Drive (VFD) control enables precise airflow settings, higher efficiencies, PLC connectivity, motor protection and non-spiking soft-starts.

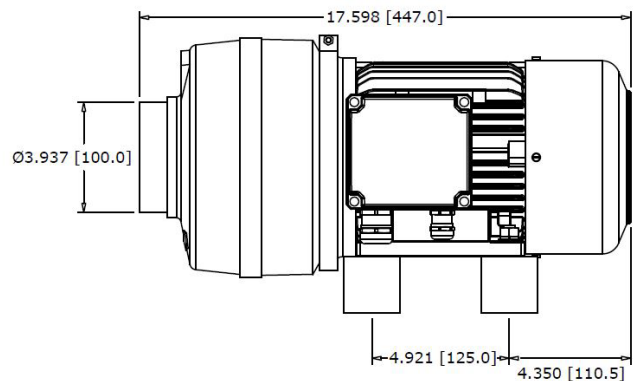
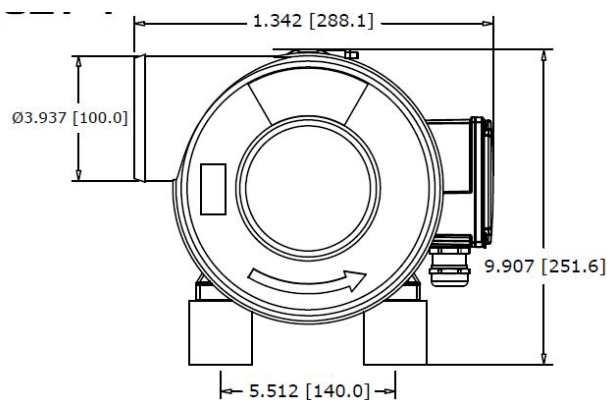

Technical Specifications

DESCRIPTION:

DirectDrive™ Technology, Single Stage Centrifugal Compressor, Oil-Less, Spindle Free Design.

DRIVE SYSTEM:

DirectDrive™ Technology, with Variable Frequency Drive Control. Integrated Motor Protection, Air Cooled Rated: 105°F[40°C]

IMPELLER:

5 Axis C355 Aluminium

AERO-BLOWER:

A356-T6 Aluminum with Integrated Lifting Eye.

HIGH-SPEED MOTOR:

TEFC, IP54, External Junction Box, 5-10HP [3.7-7.5kW] 3-Phase, 190-220, 390-480 and 600VAC, 50/60Hz, Thermister, 105°F [40°C] Ambient.

WEIGHT:

67lbs.[31kg]

CONNECTIONS:

Inlet 4"Ø [102mm], Outlet 4"Ø [102mm], 360° Rotation.

WARRANTY:

1 Year.

Performance Curve: **JET-1**[™]

