



# UC SERIES

## MODEL UC1518L (AA - 1-1/2X1X8)



### UC1518L PERFORMANCE 3500 RPM, 60 Hz

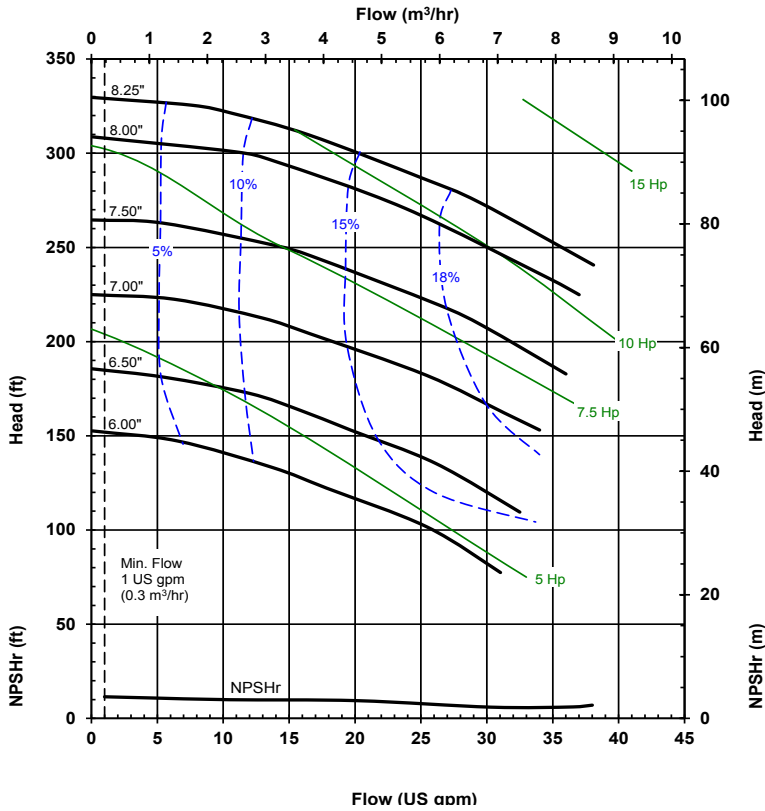

### UC1518L PERFORMANCE 2900 RPM, 50 Hz

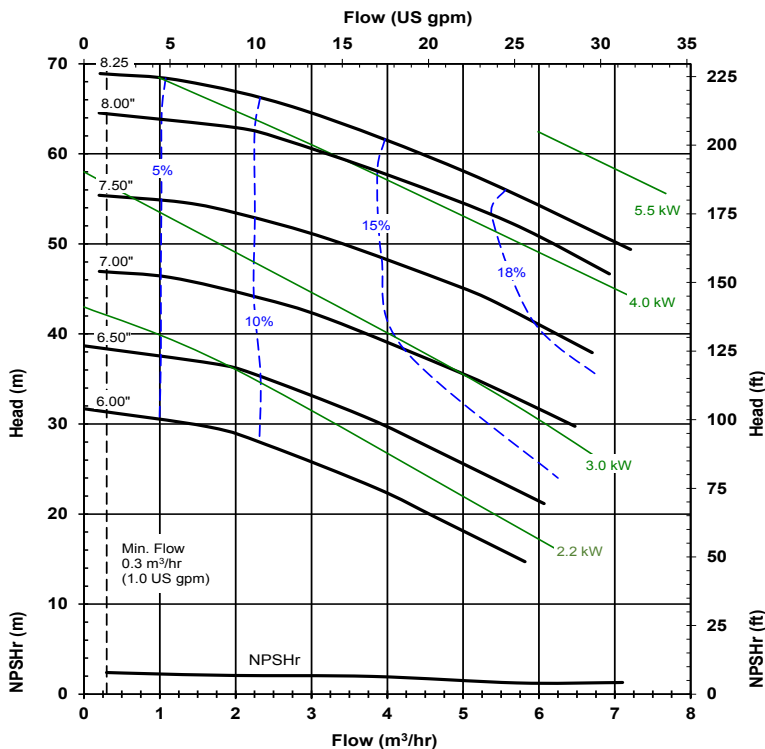

## FEATURES

- Durable, corrosion-resistant Tefzel® lined ductile iron casing
- Casing meets ANSI B73.1m & B73.3 for foot and flange location
- Powerful neodymium magnets for dependable, leak-free operation
- Modified concentric volute reduces radial thrust load
- Rear sealing ring and balance holes balance axial thrust
- Dual bushings provide optimum alignment
- Suction shaft support with integral straightening vanes
- Easy-set measurement free outer drive
- Back pull-out design
- Exclusive vapor protection package to protect outer magnetic drive and motor face from corrosive fumes
- Replaceable 2-piece impeller and drive hub
- Run dry capability with carbon or Dri-Coat SiC bushing
- Casing drain standard
- Specific gravity over 1.8
- Accepts standard NEMA 143-256 or IEC 90-160 motor frames
- ANSI or ISO flange mountable
- ATEX certified models available



## TYPICAL APPLICATIONS

- Paper Mills
- Water treatment
- Plating & metal finishing
- Chemical manufacturing, blending, distribution
- Fume scrubbers
- Pharmaceuticals
- Truck loading/unloading
- Metals manufacturing

## TYPICAL CHEMICALS

- Sodium hydroxide
- Sulfuric acid
- Hydrochloric acid
- Sodium hypochlorite
- Plating solutions
- Corrosive blends
- Solvents
- Wastewater

\*Tefzel® Fluoropolymer Resin is a registered trademark of DuPont

# UC SERIES

Item No.	Description	Construction
1	Casing	Cast ductile iron, DuPont Tefzel® (ETFE) lined
2	Shaft support	Carbon fiber filled ETFE
2A	Front thrust ring	Alpha sintered silicon carbide
3	Impeller	Carbon fiber filled ETFE
3A	Impeller thrust washer	Alpha sintered silicon carbide
4	Inner drive	Neodymium iron boron magnets encapsulated in ETFE
4A	Bushing	Alpha sintered silicon carbide, Dri-Coat silicon carbide, or carbon
4B	Bushing spacer	PTFE
4C	Rear sealing ring	GF molybdenum disulfide-filled PTFE
5	Shaft	Alpha sintered silicon carbide
6	Barrier	Molded carbon fiber filled ETFE liner with woven glass reinforced vinyl ester external shell
6A	Barrier thrust ring	High purity alumina ceramic
7	Clamp ring	Steel
8	Outer drive magnet	Nickel-plated neodymium iron boron magnets/steel
9	Motor adapter	Ductile iron
10	O-ring	FKM, EPDM, Kalrez®, Simriz®, or Aflas®
11	Vapor Protection O-Rings	Buna

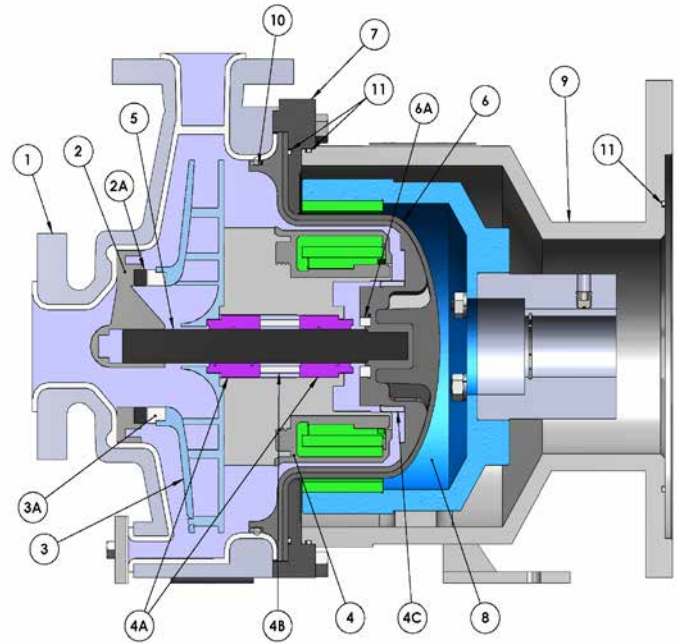

Kalrez® is a registered trademark of DuPont Performance Elastomers  
 Simriz® Perfluoroelastomer is a registered trademark of Simrit® division of Freudenberg-NOK.  
 Aflas® is a trademark of the Asahi Glass Co., Ltd.  
 Fluorosin® is a registered trademark of Quadrant DSM Engineering Plastic Products.

## SPECIFICATIONS

HP (kW)	Impeller Diameter	Suction	Discharge	Max. Flow 3500 rpm		Max. Head 3500 rpm		Max. Working Pressure psi (Bar)	Max. Viscosity cP	Max. Specific Gravity	Max. Temp. °F (°C)
	in (cm)	in (cm)	in (cm)	gpm	m <sup>3</sup> /hr	ft.	m				
3 - 20 (1.1 - 15.0)	6 - 8-1/4 (15.2 - 20.9)	1-1/2 (3.81)	1 (2.54)	38	8.6	330	101	175 (12)	200	1.8	250 (121)

Note: Impeller trims available every 1/8" (.32 cm) between the smallest and largest diameters.

## DIMENSIONS

### SIDE VIEW

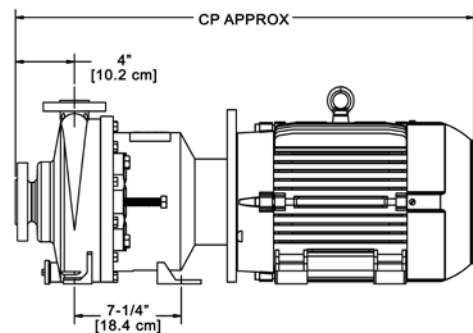

ANSI 150# & ISO/DIN PN20 flanges are in compliance with bolting dimensions only.

Motor Frames	CP (approx.)	
	(in)	(cm)
<b>NEMA</b>		
143-145TC	23-17/32	59.8
182/184TC	28-3/32	71.3
213/215TC	31-5/32	79.1
254/256TC	34-9/32	81.7
<b>IEC</b>		
90	23-19/32	59.9
100/112	25-1/32	63.6
132	31-3/32	79
160	34-27/32	88.5

### FRONT VIEW

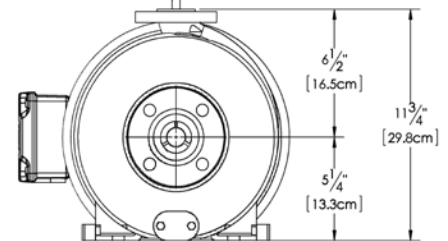

### BOTTOM VIEW

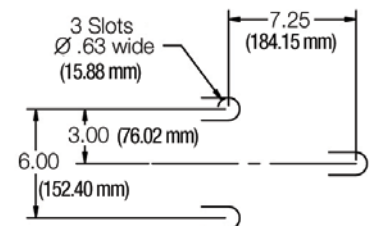

finishthompson.com

### FINISH THOMPSON INC. - UNITED STATES

921 Greengarden Road | Erie, PA 16501  
 800.934.9384 | ph 814.455.4478 | fx 814.455.8518  
 email fti@finishthompson.com

### FINISH THOMPSON INC. - GERMANY

Otto-Hahn-Strasse 16 | Maintal, D-63477 Germany  
 49 (0)6181-90878-0 | fx 49 (0)6181-90878-18  
 email fti@finishthompson.com