

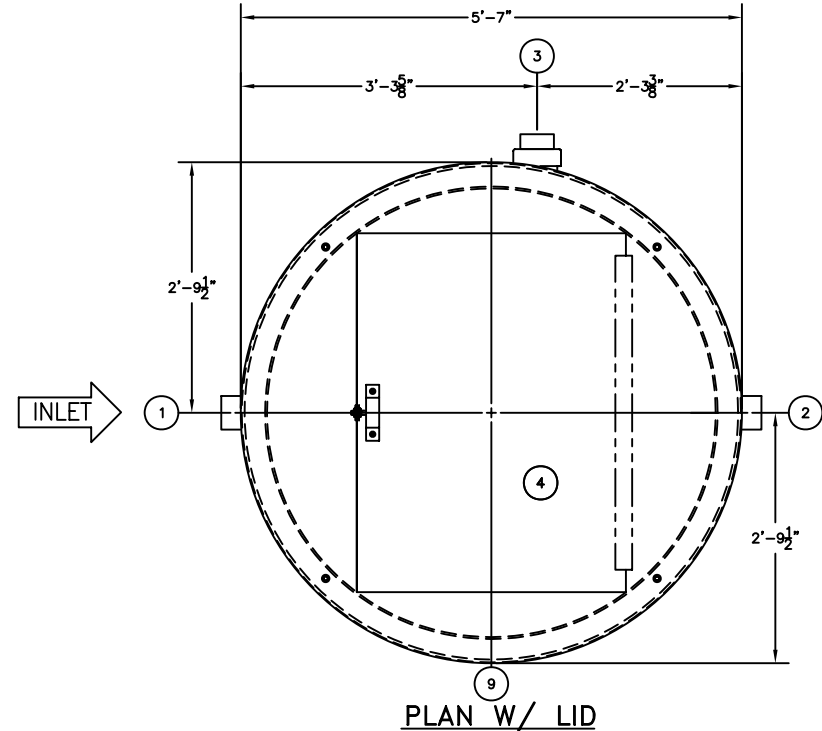
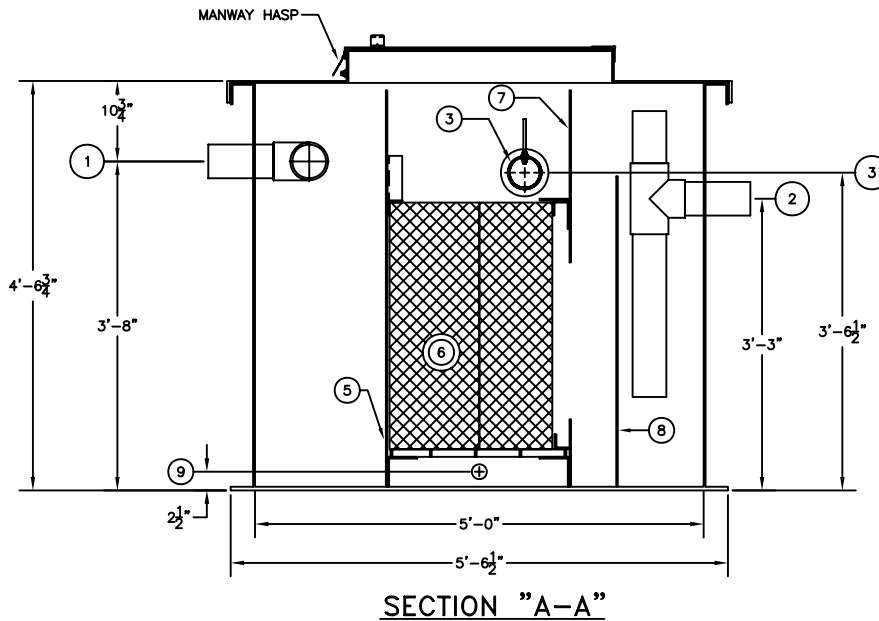

### ASSEMBLY LIST

- ① 4"Ø INLET, PIPE STUB
- ② 4"Ø OUTLET, PIPE STUB
- ③ 4"Ø ROTARY PIPE SKIMMER, W/ 4"Ø OIL OUTLET, PIPE STUB
- ④ 3'-0" x 4'-0" MANWAY
- ⑤ INLET BAFFLE
- ⑥ VERTICAL TUBE COALESCERS
- ⑦ OIL RETENTION BAFFLE
- ⑧ WEIR WALL
- ⑨ 1"Ø DRAIN COUPLING, FPT W/ PLUG

### NOTES

1. PIPE AND FITTINGS ARE TO BE ONE OF THE FOLLOWING TYPES:  
SCH. 40, PVC - STANDARD  
SCH. 80, PVC  
SCH. 40, CPVC  
SCH. 80, CPVC  
SCH. 80, PVC  
FRP BISPHENOL  
FRP VINYL ESTER
2. TANKS ARE TO BE CONSTRUCTED WITH ONE OF THE FOLLOWING RESIN TYPES:  
ISOTHALIC POLYESTER - STANDARD  
BISPHENOL A - POLYESTER  
VINYL ESTER
3. MODIFICATIONS AND SPECIAL EQUIPMENT TO SUITE SPECIFIC CUSTOMER REQUIREMENTS ARE AVAILABLE BY FACTORY UPON APPROVAL BY AFL'S ENGINEERING DEPARTMENT.
4. TANKS CAN BE FABRICATED WITH A BOTTOM FLANGE WHEN ANCHORING IS REQUIRED.



 <b>INDUSTRIES, INC.</b> 1751 WEST 10TH STREET, RIVIERA BEACH, FLA. 33404		
SCALE: NONE	THIS DRAWING AND SPECIFICATION IS THE PROPERTY OF AFL INDUSTRIES, INC. 1751 WEST 10TH STREET, RIVIERA BEACH, FLA. 33404 AND SHALL NOT BE REPRODUCED WITHOUT WRITTEN PERMISSION.	DRAWN BY: TMB
DATE: 5/29/07		CHECKED BY:
MODEL: CVF-5A-660-50-S-0		AFL JOB No. 5204
JOB: AFL INDUSTRIES	DRAWING No. 3S2574	
		FILE: CVF-5A-660-50-S-0 5/29/07