

PLAN W/O LID

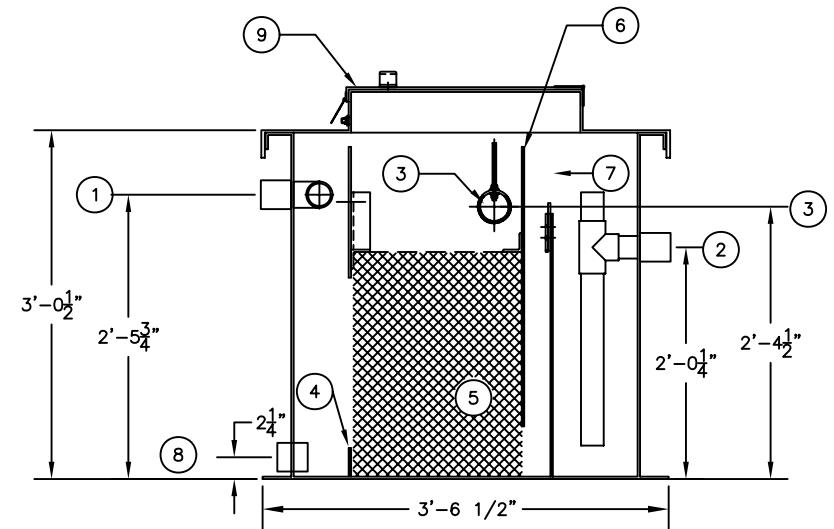

SECTION "A-A"

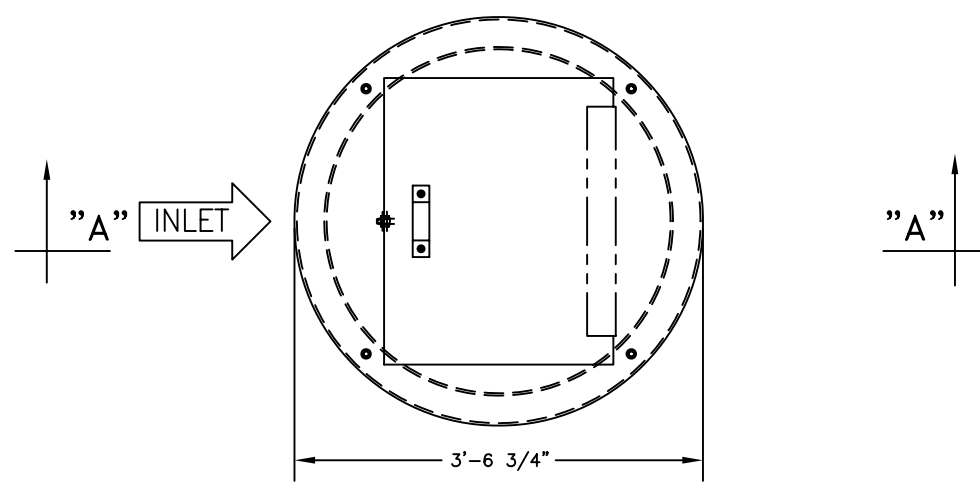

PLAN W/ LID

ASSEMBLY LIST

- ① 2" ϕ INLET, PIPE STUB
- ② 2" ϕ OUTLET, PIPE STUB
- ③ 3" ϕ ROTARY PIPE SKIMMER/OIL OUTLET, PIPE STUB
- ④ INLET BAFFLE
- ⑤ VERTICAL TUBE COALESCERS
- ⑥ OIL RETENTION BAFFLE
- ⑦ WEIR WALL
- ⑧ 1" ϕ DRAIN COUPLING, FNPT W/ PLUG
- ⑨ 2'-6" x 2'-0" MANWAY

NOTES

1. WITHOUT WRITTEN CONSENT FROM AFL INDUSTRIES, INC., DO NOT:
 - A. DRILL HOLES OR OTHERWISE PUNCTURE THE FIBERGLASS SKINS OF THE UNIT.
 - B. MOUNT ANY EQUIPMENT OR ACCESSORY ON THE UNIT.
 - C. REMOVE ANY EQUIPMENT OR ACCESSORY FROM THE UNIT.
 - D. FLOOD THE UNIT OR RESTRICT THE OUTFLOWS.
2. AFL REQUIRES A FLEXIBLE COUPLING TO BE INSTALLED BETWEEN THE TANK AND CUSTOMER'S CONNECTING PIPES TO ELIMINATE EXCESSIVE LOADING ON TANK FLANGES.
3. DIMENSIONAL TOLERANCE $\pm 1/2"$.
4. ALL TANK FLANGES FURNISHED BY AFL ARE 150# FLAT FACE FLANGES.
5. ALL NOZZLE PROJECTIONS ARE 4" UNLESS NOTED OTHERWISE.
6. ALL FLANGE BOLT HOLE PATTERNS TO STRADDLE CENTERLINES.

 INDUSTRIES, INC. 1751 WEST 10TH STREET, RIVIERA BEACH, FLA. 33404		
SCALE: NONE	THIS DRAWING AND SPECIFICATION IS THE PROPERTY OF AFL INDUSTRIES, 1751 WEST 10TH STREET, RIVIERA BEACH, FLA. 33404 AND SHALL NOT BE REPRODUCED WITHOUT WRITTEN PERMISSION.	DRAWN BY: BRB
DATE: 12/9/03		CHECKED BY:
MODEL: CVF-3A-159-10-S-0		AFL JOB No. AFL
JOB: AFL		DRAWING No. 3S2127
		FILE: 3-159-10 12/9/03