



Valve Position Monitors



APL 5 Series
CSA Approved Type 4X/6
Class I, Div 1, Grps B, C, D T6
Class II, Div 1, Grps E, F, G
Class III



NEW:
APL-9 Series
Stainless Steel
Type 4X, IP 67

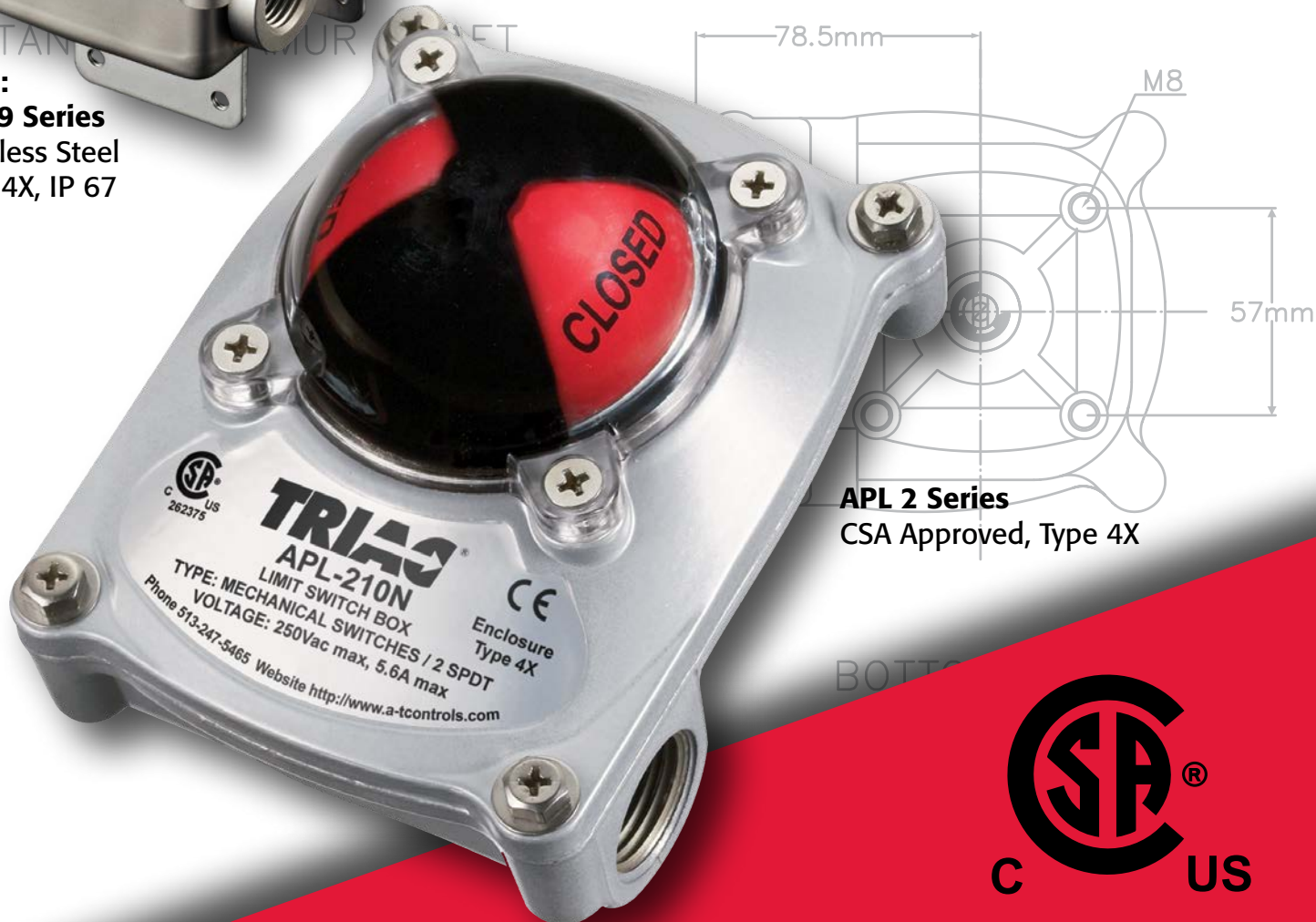

APL 2 Series
CSA Approved, Type 4X



TRIAQ® APL Series Limit Switches

The Triac APL Series Limit Switches feature high quality, easy to use multiple option switch boxes for rotary actuators. Their die cast aluminum housings are powder coated for corrosion resistance and feature red/green visual indicators, quick-set cams and easy access terminal strips. These economical switch boxes offer numerous switch, sensor and transmitter options to handle most applications found in today's process and industrial markets.

APL-2 Series "Compact" Switch

- CSA Approved, Type 4X
- Die-cast aluminum powder coated enclosure
- Solid and compact design
- Dome visual indicator (3-way available)
- Dual 1/2" NPT conduit entries, 8 pts. on terminal strip
- Quick-set spring loaded cam
- Captive cover bolts
- NAMUR low profile brackets
- Available Switches 10, 18, 20 & 23
- Ambient temperature range -20°C to 80°C (-4°F to 176°F)



APL-210



APL-218

Simple device for intrinsically safe applications



NEW: APL-9 Series Stainless Steel

- Type 4X, IP 67
- 304 Stainless Steel enclosure
- Stainless Steel shaft & captive cover bolts
- Dome visual indicator (3-way available)
- Dual 1/2" NPT conduit entries, 8 pts. on terminal strip
- Quick-set spring loaded cam
- NAMUR stainless steel bracket
- Multiple options - up to four switches, intrinsically safe, reed type sensors (See options 12, 20, and 30 on page 7)
- Ambient temperature range -20°C to 80°C (-4°F to 176°F)



APL-3 Series



- CSA Approved, Type 4X
- Die-cast aluminum powder coated enclosure
- Rugged and flexible design
- Dome visual indicator (3-way available)
- Dual 1/2" NPT conduit entries, 8 pts. on terminal strip
- Quick-set spring loaded cam
- Captive cover bolts
- NAMUR brackets
- Multiple options - up to four switches, various mechanical, proximity and reed type sensors, feedback potentiometers and 4-20mA transmitters
- Ambient temperature range -20°C to 80°C (-4°F to 176°F)



APL-4 Series



- CSA Approved, Class I, Division 1, Groups C & D T6
Class I, Zone 1, AEx d IIB, T6, Ex d IIB, T6, Type 4X/6, IP 66/67/68
- ATEX/IECEX rating available: Ex d IIB T6 Gb
(*Use ATEX suffix to denote this option. Ex: APL-410N-ATEX)
- Dome visual indicator (3-way available)
- Dual 3/4" NPT conduit entries, 8 pts. on terminal strip
- Quick-set spring loaded cam
- Captive cover bolts
- NAMUR brackets
- Multiple options - up to four switches, various mechanical, proximity and reed type sensors, feedback potentiometers and 4-20mA transmitters
- Ambient temperature range -20°C to 60°C (-4°F to 140°F)



APL-5 Series



Available in Stainless Steel

- CSA Approved: Type 4X/6, IP 66/67
Class I, Division 1, Group B, C & D T6;
Class II, Division 1, Group E, F, G; Class III
Class I, Zone 1, AEx d IIC, T6;
Class II, Zone 21, AEx tb IIIC T65°C Db
Ex d IIC, T6; Ex tb T65°C Db
- ATEX/IECEX rating available:
Ex d IIC T6 Gb; Ex tb IIIC T85°C Db, IP67
(*Use ATEX suffix to denote this option. Ex: APL-510N-ATEX)
- Dome visual indicator (3-way available)
- Dual 3/4" NPT conduit entries, 8 pts. on terminal strip
- Quick-set spring loaded cam
- Screw on enclosure lid with spring loaded cover bolts - unique design to hold bolts inside cover
- NAMUR brackets
- Multiple options - up to four switches, various mechanical, proximity and reed type sensors, feedback potentiometers and 4-20mA transmitters
- Ambient temperature range -20°C to 60°C (-4°F to 140°F)
- Low temp option down to -50°C (-58°F) with C1, C3 switches only



APL Series Dimensions (IN)

APL-2 Series

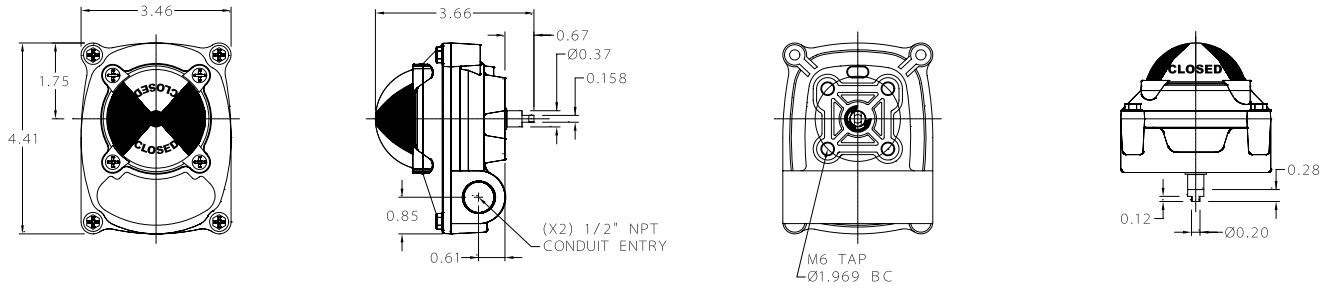

APL-3 Series

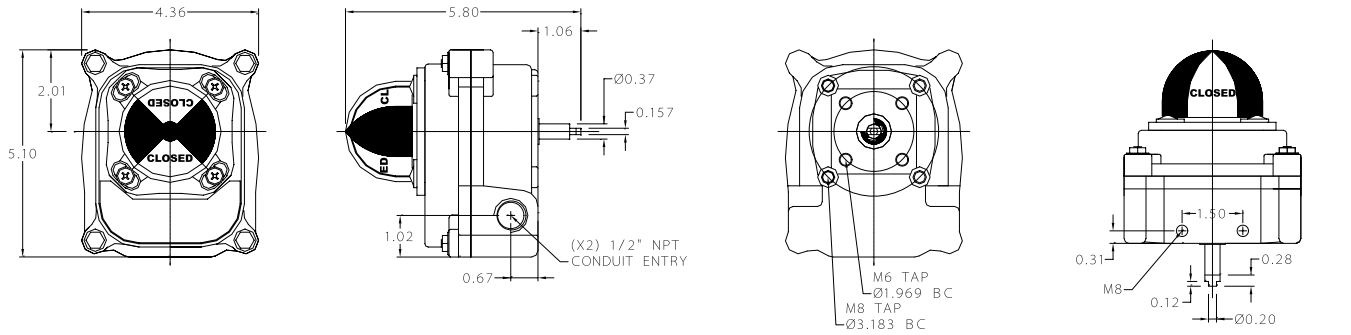

APL-4 Series

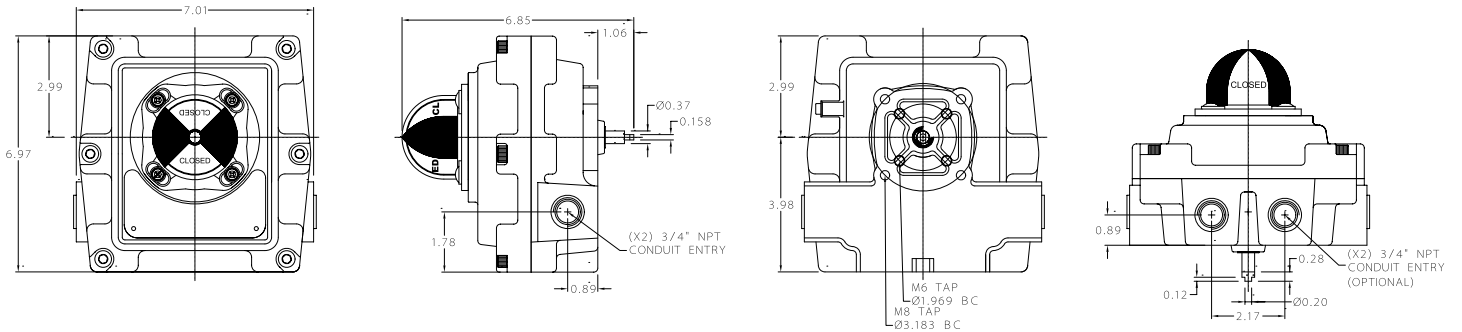

APL-5 Series

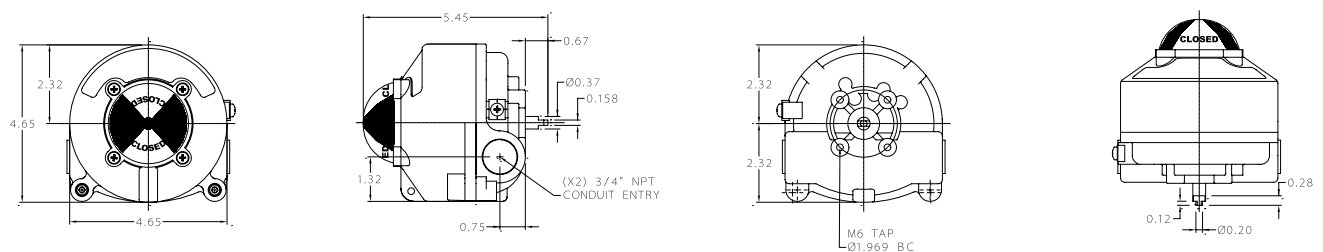

APL Series Dimensions (IN)

APL-9 Series

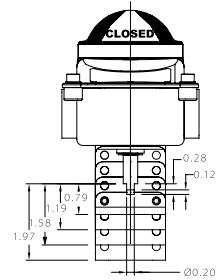
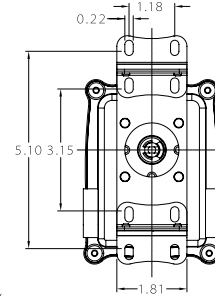
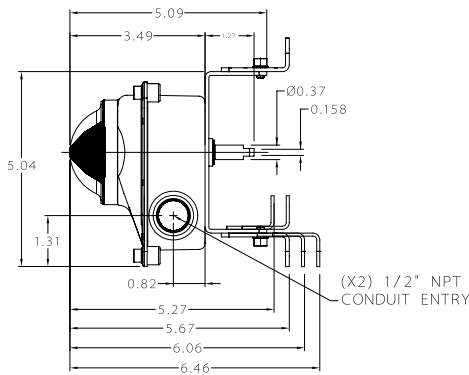
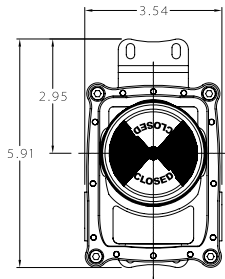

Wiring Schematics

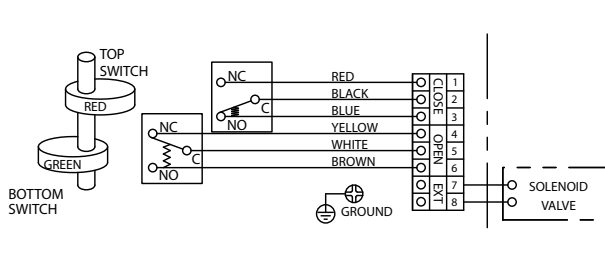

(2) SPDT SWITCHES

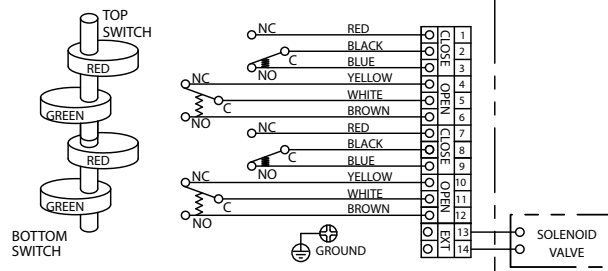

(4) SPDT SWITCHES

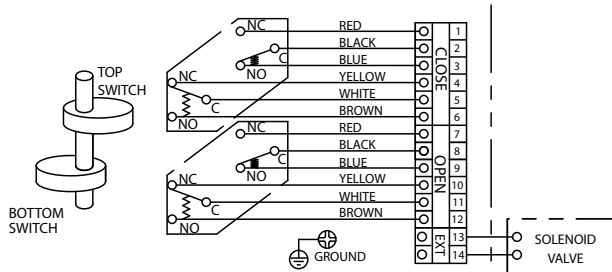

(2) DPDT SWITCHES

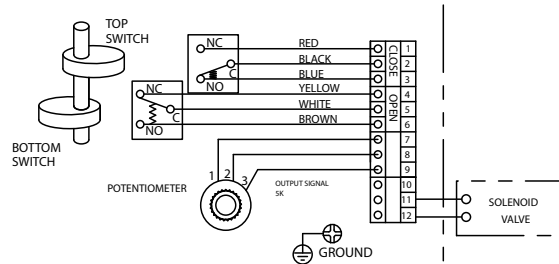

**(2) SPDT SWITCHES
5K OHM POTENTIOMETER**

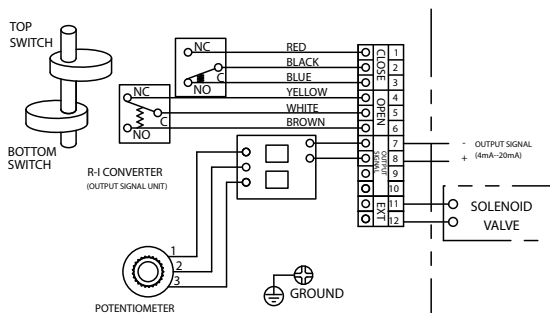

**(2) SPDT SWITCHES
4-20mA TRANSMITTER**

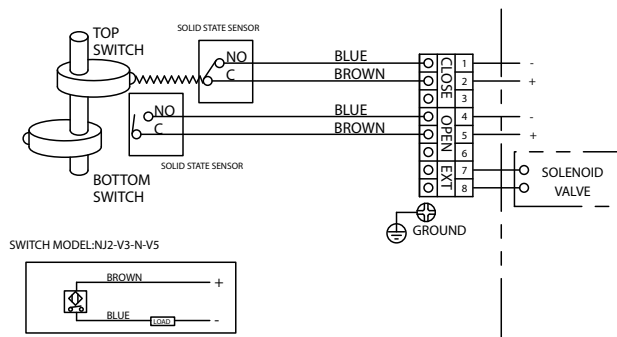

**(2) P&F NJ2-V3-N
SOLID STATE SENSORS**

NOTE
TYPE: PROXIMITY SWITCHES VOLTAGE: 5V-30V DC

Solenoid Valve Integration: APL-5 Series & ASCO Solenoid

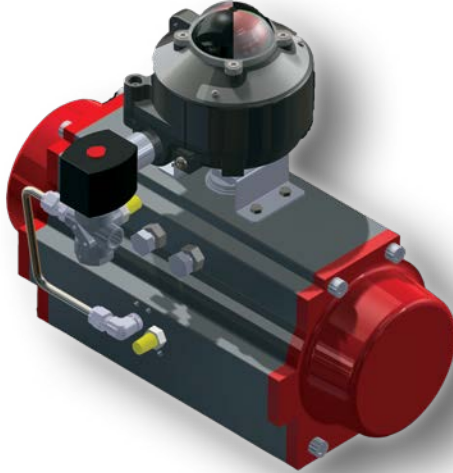

3-Way Solenoid	- Spring Return
+EF8320G184	Brass Body
+EV8320G202	303 Stainless Steel Body
+EV8316G381V-D24	1.4 Watt Low-powered Stainless Steel Solenoid
4-Way Solenoid	- Double Acting
+EF8342G001	Brass Body
+EV8342G701	304 Stainless Steel Body

- Mounting Options
1. Direct Mount
 2. Pipe Mounted
 3. Braided

Triac Cobra Limit Switches:

The Triac Cobra hermetically sealed proximity switches have a patent pending design for high (C1) and low (C3) current applications. This design has the current capability of a mechanical switch with the reliability of solid state sensors with up to 10,000,000 cycles. We recommend using our Cobra C3 (Gold Bifurcated) limit switch for low current and intrinsically safe applications.

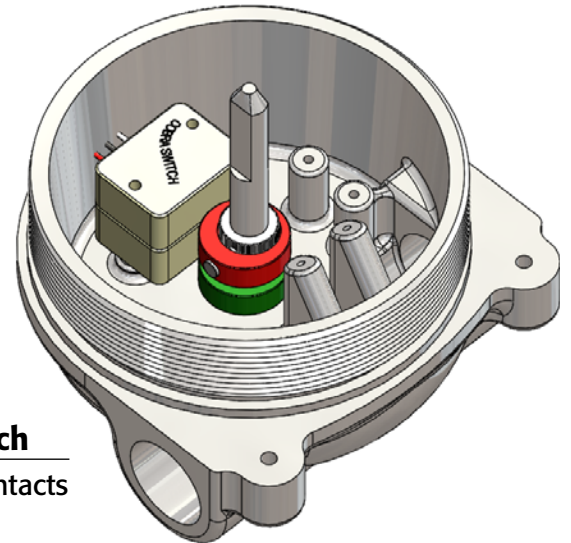

C1 Hermetically Sealed Proximity Switch

Silver Oxide SPDT Contacts

Contact Rating

5 A resistive, 3 A inductive, 28VDC

5 A resistive or inductive. 250VAC

10,000,000 Cycles Mechanical Life

C3 Hermetically Sealed Proximity Switch

Gold Bifurcated SPDT Contacts

Contact Rating

1 A resistive, 0.5 A inductive, 28VDC

1 A resistive or inductive. 125VAC

10,000,000 Cycles Mechanical Life

Optional Features:



3-Way Dome Indicator
T-port or L-Port

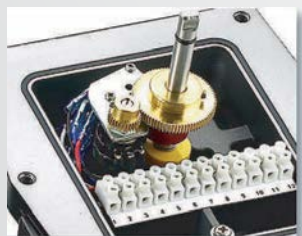

Potentiometer
500~10K Ohm (Excludes APL-2)



Position Transmitter
12.5VDC to 37VDC,
4-20mA (Excludes APL-2)

How to Order APL Series



Series	Description	CSA Ratings - Housing Max
APL-2	CSA approved Type 4X - Compact Enclosure	5.6A Max, 250VAC Max
APL-3	CSA approved Type 4X - Standard Enclosure	5.6A Max, 250VAC Max
APL-4	CSA approved Class I, Division 1, Groups C & D T6; Class I, Zone 1, AEx d IIB, T6, Ex d IIB, T6, Type 4X/6, IP 66/67/68 - Large Enclosure	4A Max, 250VAC Max
APL-5 [†]	CSA approved: Class I, Div 1, Grps B, C & D T6; Class II, Div 1, Grps E, F, G; Class III — Class I, Zone 1, AEx d IIC, T6, Ex d IIC, T6; Class II, Zone 21, AEx tb IIIC T65°C Db; Ex d IIC, T6; Ex tb T65°C Db; Type 4X/6, IP 66/67 - Threaded Enclosure	4A Max, 250VAC Max
APL-9	Type 4X, IP67 - 304 Stainless Steel housing, shaft, captive cover bolts & bracket (CSA Pending)	5.6A Max, 250VAC Max

Switch Type	Description	Contact Ratings - Max	2	3	4	5	9
APL-			2	3	4	5	9
10	(2) SPDT Mechanical	16A@125/250VAC, 10A@30VDC, 0.6A@125VDC	▪	▪	▪	▪	▪
12	(4) SPDT Mechanical	16A@125/250VAC, 10A@30VDC, 0.6A@125VDC		▪	▪	▪	▪
14	(2) DPDT Mechanical	20A@125/250VAC, 1A@125VDC, 1HP@125VAC			▪	▪	
15	(2) SPDT Mechanical, +5K Ohm Potentiometer	16A@125/250VAC, 10A@30VDC, 0.6A@125VDC		▪	▪	▪	
16	(2) SPDT Mechanical, + 4-20mA Transmitter	16A@125/250VAC, 10A@30VDC, 0.6A@125VDC +12.5VDC to 37VDC		▪	▪	▪	
18	(2) SPDT Gold Plated — Simple device for Intrinsically Safe applications	Resistive load: 0.1amps @ 125VAC/8VDC/14VDC/30VDC		▪	▪	▪	▪
20	(2) P&F NJ2-V3-N, 2-wire, NAMUR Output, Not Amplified, (Requires Intrinsically Safe barrier)	15mA Max, Nominal Voltage 8VDC		▪	▪	▪	▪
21	(2) Autotonics PSN17-5DNU, 3-wire NPN Inductive Proximity Solid State Sensor, 10-30VDC, 200mA max load	NOT INCLUDED in CSA certification			▪	▪	
23	(2) P & F NBB2-V3-E2 Limit Switch, 3-Wire, PNP Sourcing	10-30VDC, 100mA @ 30VDC		▪	▪	▪	▪
30	(2) SPST Reed Proximity, 50 Watts Max	0.4A @ 125VAC, 1A @ 24VDC			▪	▪	▪
C1	(2) SPDT COBRA Proximity, Silver Contacts Patent 9,620,317 (CSA pending)	5A MAX, 250VAC Max, 4A Res, 2A Ind, 28VDC, Rated for 10,000,000 operations				▪	
C3	(2) SPDT COBRA Proximity, Gold Bifurcated Contacts Patent 9,620,317 (CSA pending)	1A MAX, 125VAC Max, 1A Res, 0.5A Ind, 28VDC, Rated for 10,000,000 operations				▪	

Enclosure Material

N	Aluminum (except on APL-9 where 304SST is standard)	▪	▪	▪	▪	▪
S	Stainless Steel (optional adder for APL-5 Series)					▪

OPTIONS Standard or Multi-Port Dome Indicator

blank	Standard 2-Way Visual Dome Indicator (Red for Closed, Green for Open)
L	3-Way Dome Indicator - L Port
T	3-Way Dome Indicator - T Port

Mounting Bracket & Assembly (Must specify model for mounted units & separate mounting kits)

-20	2R20 thru 2R300, 30mm-80mm - 20mm high pinion - Stainless Steel
-30	2R500 thru 2R3500, 30mm-130mm - 30mm high pinion - Stainless Steel
-HD	THD Series Heavy Duty Actuators
-MAN	Manual Valve mounting

NOTES: APL-210N contact switch rates are: 10.1A @ 125/250VAC, 4A @ 30VDC, 0.4A @ 125VDC

- Conduit plugs supplied with the switch box are for transit purposes only. To ensure protection, any unused conduit entry must be closed with appropriate conduit plug.

[†] All switches can be used in Class I, Div 2 areas, but a certified seal-off filling is required during installation.



Triac

EX Series Limit Switches

The Triac EX Series

hazardous location Limit Switch provides a compact design and low cost for both visual and remote electrical indication of rotary valve/actuator position. The heavy duty design and wide variety of options make the EX Series the ideal multi-purpose Limit Switch for use in NEMA 4, 4X, 7 and 9 applications.

Features:

- **Aluminum Housing:** Polyester Powder Coating
- **Twin Shaft Body Design:** The primary shaft is located in the housing base and connects to a mating shaft located in the housing cover. This twin shaft feature allows easy and accurate housing assembly by eliminating the blind-hole configuration associated with competitive switch boxes.
- **Multiple Switch Options:** Wide variety of mechanical, proximity and inductive switch options provide the most effective and economical choice for each specific application.
- **Visual Position Indication:** The 3D rotor provides high visibility confirmation of valve/actuator position. The splined retainer allows adjustment to coincide with the exact valve position.
- **“Easy-Set” Cams:** Splined, spring loaded and independently adjustable. This design offers tool-free calibration and positive vibration resistant engagement.
- **Multiple Cable Entries:** Standard with two 1/2" NPT cable entries with option for third 1/2" or 3/4" NPT cable entry.
- **Standardized Mounting:** ISO F05 mounting pattern and VDI/VDE3845 shaft
- **Options:** AS-i digital communication interface card, 3-position dribble control, 4-20mA feedback transmitter, special terminal strips, NAMUR mounting brackets.

Specifications

Temperature Range

(may vary due to switch range & approvals)

Operating temperature range DIV 1
-13°F to 176°F (-25°C to 80°C)

Operating temperature range DIV 2
-40°F to 176°F (-40°C to 80°C)

Electrical: according to switch option

Enclosure Approvals

UL and cULus, NEMA 4, 4X, 7 & 9, IP65 & 67

Switch Approvals

Class I Division 1 Groups C, D

Class I Division 2 Groups A, B, C, D
(proximity sensors only)

Class II Division 1 Groups E, F, G

Class II Division 2 Groups F, G
(proximity sensors only)

Gold plated versions can also be used on intrinsically safe applications.

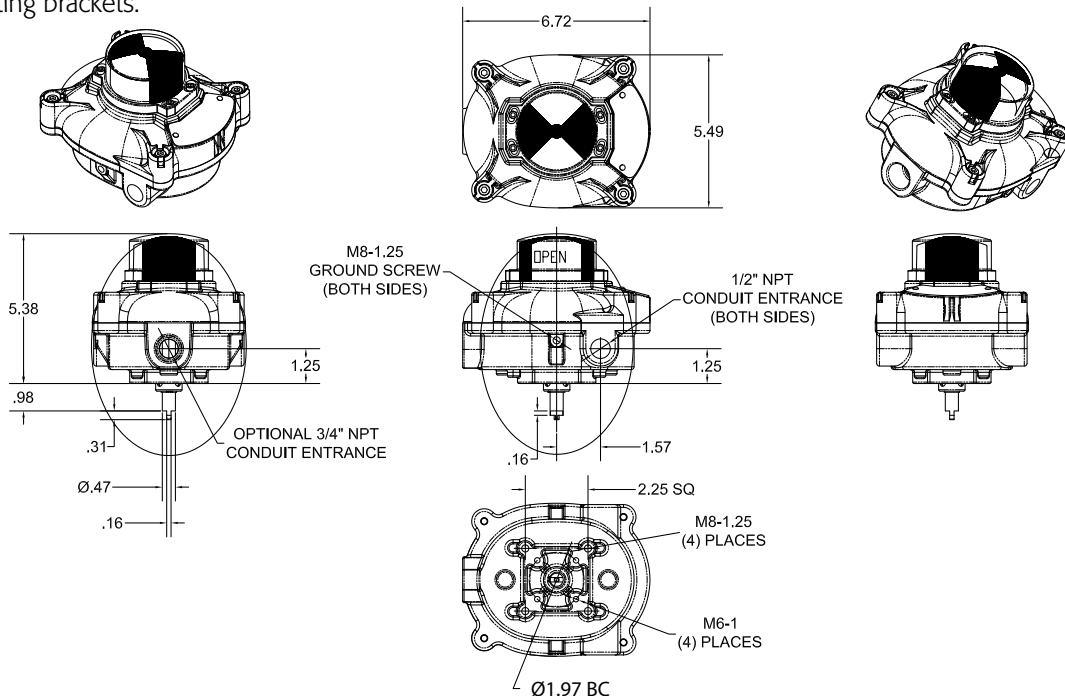

Triac: UL Listed and Explosion Proof Limit Switches

EC/ES Series



- Available in Aluminum (EC) or 316SST (ES) Housing
- UL Listed NEMA 4, 4X, Weather Proof
- Visual indicator options
- Dual threaded conduit entries with extra terminals
- High Resolution Splined Cam
- Temperature Range: -40°F (-40°C) to 176°F (80°C)
- ISO F05 mounting pattern and VDI/VDE3845 shaft
- Available with 3-way Pneumatic valve
- Multiple options - up to three switches, various mechanical, proximity and reed type sensors, feedback potentiometers and 4-20mA transmitters, AS-i interface

EY Series



- Low Copper Aluminum Housing
- UL Listed NEMA 4, 4X, 7 & 9, Explosion Proof & Weather Proof Class I, Division 1, Groups B, C & D Class II, Division 1, Groups E, F & G
- Visual indicator with twin shaft design
- Up to four conduit entries with extra terminal options
- High Resolution Splined Cam
- Temperature Range: -40°F (-40°C) to 176°F (80°C) (T6)
- Low Temperature rating down to -76°F (-60°C) available on request (available with 1D Switch option only)
- ISO F05 mounting pattern and VDI/VDE3845 shaft
- Multiple options - up to six switches, various mechanical, proximity and reed type sensors, feedback potentiometers and 4-20mA transmitters

EW Series



- 316 Stainless Steel Housing
- UL Listed NEMA 4, 4X, 7 & 9, Explosion Proof & Weather Proof Class I, Division 1, Groups B, C & D Class II, Division 1, Groups E, F & G
- Visual indicator options with twin shaft design
- Up to four conduit entries with extra terminal options
- High Resolution Splined Cam
- Temperature Range: -40°F (-40°C) to 176°F (80°C) (T6)
- Low Temperature rating down to -76°F (-60°C) available on request (available with 1D Switch option only)
- ISO F05 mounting pattern and VDI/VDE3845 shaft
- Multiple options - up to six switches, various mechanical, proximity and reed type sensors, feedback potentiometers and 4-20mA transmitters

How To Order

UL Listed and Explosion Proof Limit Switches



Series	Description
EC	Aluminum housing, UL Listed NEMA 4/4X (Note 3)
ES	Stainless Steel housing, UL Listed NEMA 4/4X (Note 3)
EX	Aluminum housing, UL Listed NEMA 4/4X, 7, 9 (Note 1 & 3)
EY	Aluminum housing, UL Listed NEMA 4/4X, 7, 9 (Note 2 & 3)
EW	Stainless Steel housing, UL Listed NEMA 4/4X, 7, 9 (Note 2 & 3) (Low Temp option - Note 5)

Indication

1	Aluminum (SST for ES & EW) cover with Standard Red/Green indicator
2	Aluminum (SST for ES & EW) cover with 3-way "L" Port
3	Aluminum (SST for ES & EW) cover with 3-way "T" Port
4	Aluminum (SST for ES & EW) cover with 3-way Block Center
A	Aluminum (SST for ES) cover with no indication (ES or EC only)
B	Polycarbonate cover with Standard Red/Green indicator (EC only)
C	Aluminum (SST for ES) cover with disc indicator (ES or EC only)
L	Polycarbonate cover with 3-way "L" Port (EC only)
T	Polycarbonate cover with 3-way "T" Port (EC only)
Z	Polycarbonate cover with 3-way Block Center (EC only)

Switch Type

Ratings (Note 4)

Switch Type		Ratings (Note 4)
0A	Mechanical SPDT Silver Plated	5amp @ 250VAC, 0.5amp @ 24VDC, resistive/inductive
0C	Mechanical SPDT Gold Plated	0.1amp @ 120VAC, resistive
0E	Mechanical DPDT Silver Plated	5amp @ 250VAC, 1/4 HP @ 125VAC, resistive/inductive
1A	Proximity Reed (w/ LED) SPST	1amp @ 125VAC, resistive
1D	Proximity Reed SPDT (Low Temp w/ EW only - Note 5)	0.25amp @ 120VAC, 0.416amp @ 48VDC, resistive
1F	Proximity Reed DPDT (EX, EY or EW only)	0.25amp @ 120VAC, 0.416amp @ 48VDC, resistive
7J	Solid State Sensor (P&F NJ2-V3-N) (Requires IS barrier)	NAMUR 2 wire, supply voltage 8VDC (Req IS barrier)
7A	Solid State Sensor (P&F NBB2-V3-US)	2 Wire, 5 to 200mA, 20 to 140V (AC or DC)
7C	Solid State Sensor (P&F NBB2-V3-E2)	3 Wire, PNP, 5 to 100mA @ 30VDC, amplified
82	Three-way Pneumatic valve (ES or EC only)	
AS	AS-i Protocol	
DA	3-Position control w/ feedback on DA actuator (EX, EY or EW only)	3 position control + position feedback for DA actuator
DB	3-Position control w/ feedback on SR actuator (EX, EY or EW only)	3 position control + position feedback for SR actuator
DC	3-Position control w/o feedback on DA actuator	3 position control, no position feedback for DA actuator
DE	3-Position control w/o feedback on SR actuator	3 position control, no position feedback for SR actuator
TA	4-20 mA Transmitter with 2 SPDT switches	4-20mA output, 9 - 30VDC (0A switch rating)
TX	4-20 mA Transmitter	4-20mA output, 9 - 30VDC (no switches)
N1	Nova V3 Proximity SPDT Silver-oxide hermetically sealed	5amp @ 250VAC, 5amp @ 28VDC, Max inductive load 4A
N3	Nova V3 Proximity SPDT gold-bifurcated hermetically sealed	1amp @ 125VAC, 1amp @ 30VDC, Max inductive load 0.5A



Switch Quantity

0	No Switches (Use with 'TX' option)
2	Two Switches
3	Three Switches - Type 0A or 0C
4	Four Switches - Type 0A (EX, EY or EW only)
5	Five SPDT Switches (for DA & DB 3-position only)
6	Six SPDT Switches - Type 0A (EY or EW only)

Terminal Strip

S	Standard terminal strip
A	AS-i terminal connection
E	Pneumatic connections (1/8") (ES or EC only)

Color/Coating

BK	Black polyester powder coated
EP	Electro-polished stainless steel (ES or EW only)

Conduit

N	1/2" NPT conduit connections
G	(2) 1/2" NPT, (1) 3/4" NPT conduit connection (EX, EY or EW only)

Mounting Bracket

-20	2R20 thru 2R300, 30-80mm - 20mm high pinion
-30	2R500 thru 2R3500, 30-130mm - 30mm high pinion
-HD	THD Series Heavy Duty Actuators

NOTE #1:

EX series has the following approval:

- Enclosure Approvals: UL and cUL, Type 4, 4X, 7 & 9, (ML FILE NO. E236166)
- Class I, Division 1 Groups C & D
- Class II, Division 1, Groups E, F & G

NOTE #2:

EY & EW series have the following approval:

- Enclosure Approvals: UL and cUL, Type 4, 4X, 7 & 9, (ML FILE NO. E236166)
- Class I, Division 1 Groups B, C, & D
- Class II, Division 1, Groups E, F & G

NOTE #3:

EC, ES, EX, EY & EW series have the following approvals:

- Enclosure Approvals: UL and cUL, Type 4, 4X, (ML FILE NO. E336774)
- Switch Approvals: UL and cUL (ML FILE NO. E236166) (Proximity Reed and Solid State Sensors only)
- Class I, Division 2, Groups A, B, C & D
- Class II, Division 2, Groups F & G

NOTE #4:

The recommended minimum load for switch type "0A", "0E", & "N1" is 50mA. All other switch types are suitable for applications as low as 1mA.

NOTE #5:

EW enclosure with 1D switch is the only combination rated to low temp applications (-76°F/-60°C).

NOTES:

*Gold plated switches are suitable for intrinsically safe applications and also hazardous locations.

*Conduit plugs supplied with the switch box are for transit purposes only. To ensure Type 4, 4X, 7 & 9 protection, any unused conduit entry must be closed with appropriate conduit plug.

Series ————— **EX 1 0A 2 S BK N-20** ————— Mounting Bracket

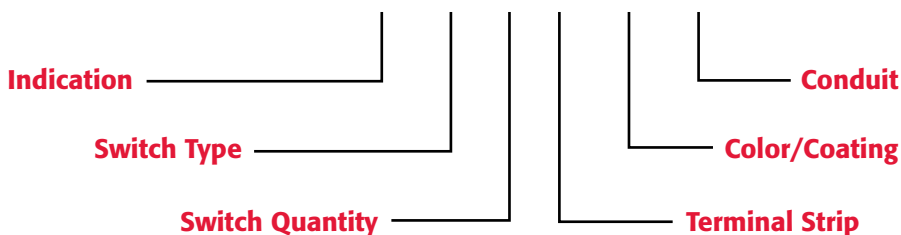

Special Application Limit Switches



HUBAS200EA13A

AS-i Omega, AS-i protocol with integral solenoid valve, limit switch, AS-i interface

HUBDB500GA45A

3-position dribble control system for spring return actuators

HUBDA500GA35A

3-position control system for double acting actuators (90° or 180° rotation)



Low Pro Sandwich Style Switch

L2F14230

Low profile switch for use with other top mounted accessories



Puck Style Low Pro Switch

Available with 2 solid state sensors or with AS-i protocol



9955 International Blvd. PHONE (513) 247-5465
Cincinnati, Ohio 45246 FAX (513) 247-5462
www.atcontrols.com sales@atcontrols.com

LimitSwitches-20190530
Copyright 2013 A-T Controls, Inc.
LIT0022

 A-T Controls, Inc.

VALVES
AUTOMATION