



A-T Controls, Inc.



# Manual and Automated Resilient Seated Butterfly Valves

Featuring the KE Series actuator for electric automation on butterfly valves up to 4"



**OS/OC Series:** Wafer and Lug Style, Class 150 Resilient Seated Butterfly Valves

**AS Series:** Lined Butterfly Valves

**NS Series:** NSF/ANSI 61 & 372 Certified and Dead-End Service Butterfly Valves



Canada Registration Numbers (CRN)



VALVE NSF/ANSI 61 ALSO CERTIFIED TO NSF/ANSI 372 <SDZD>



Featuring **TRIAO** CONTROLS Actuators and Accessories

## A-T Controls Butterfly Valves

cover a wide range of industries from General Purpose to Chemical, Food and Beverage, Pulp and Paper, Waste Water applications and more. A-T Controls Butterfly Valves are designed to comply with MSS-SP-67 and API-609 and are tested to comply with API-598 standards. They are compatible with ANSI 125/150 flanges.



### Standard Materials of Construction and Specifications

#### **Body**

Ductile Iron (Stainless Steel available)

#### **Disc**

Nickel Plated Ductile Iron (316SS, Aluminum Bronze, Nylon Coated Ductile iron, Undercut 316, Undercut Aluminum Bronze) . . . others may be available on request

#### **Seat**

EPDM (Buna-N, Food grade EPDM, High temp EPDM, Viton®, PTFE over EPDM) . . . others may be available on request

#### **Stem**

420SS (431SS, 17-4 PH® and others available)

#### **Stem Bushing**

PTFE (Lubricated Bronze available)

#### **Stem Seal**

Buna (Viton® available)

Each body is cast, precisely machined and epoxy-coated to meet rigid tolerances.

Multiple seat and disc material options are available to meet a wide variety of process applications.

Square Stem design facilitates direct mounting of actuators.

Each stem is machined to fit tightly into the upper disc for smooth operation and minimal hysteresis.

Bushings are available in PTFE and lubricated bronze. Both are corrosion resistant with minimal effect on valve torque.

Bi-directional, bubble tight shutoff for full pressure differential.

## Wafer and Lug Style

Sizes 1 1/2" - 36" in Stock

(larger sizes available)

Sizes 1 1/2" - 12" rated to 200 psi

(PTFE seats rated to 150 psi)

Sizes 14" - 36" rated to 150 psi

(PTFE seats rated to 90 psi)

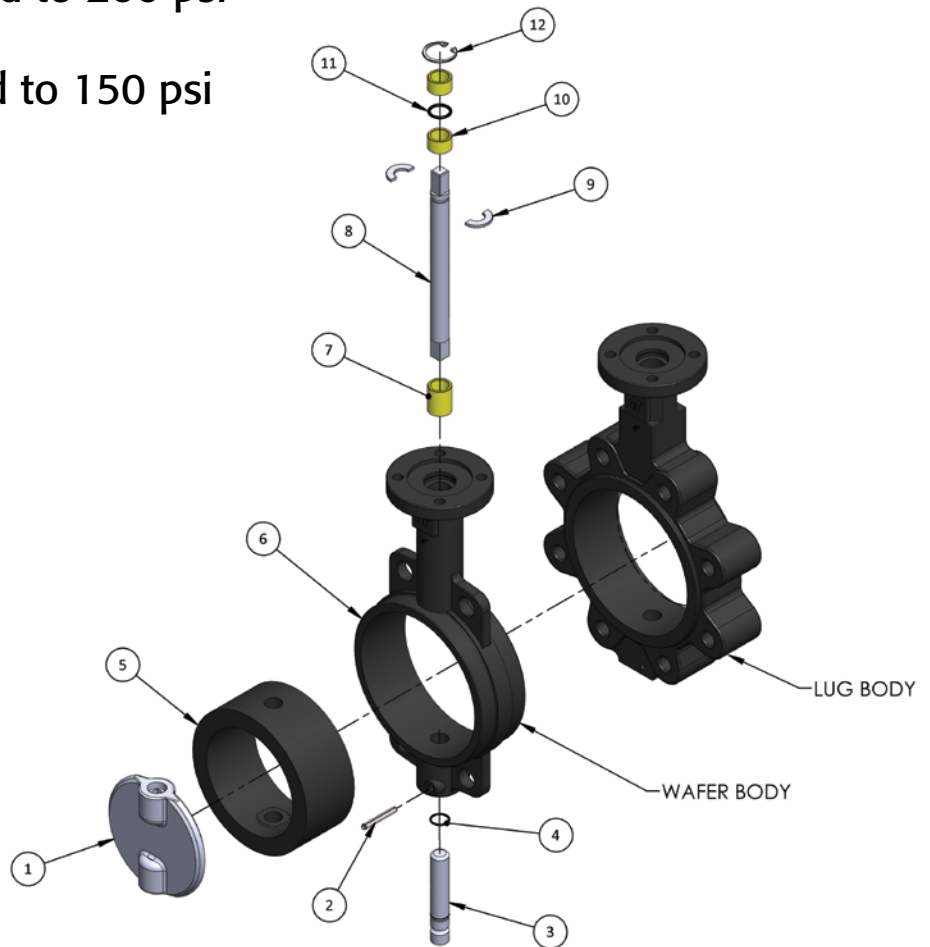

ITEM	QTY.	DESCRIPTION	MATERIAL	OPTIONAL MATERIALS
1	1	DISC	DUCTILE IRON - ENP PLATED	ALUMINUM BRONZE, 316 STAINLESS STEEL, NYLON COATED DUCTILE IRON
2	1	LOWER SHAFT RETAINER PIN	ASTM A-582	
3	1	LOWER SHAFT	420 STAINLESS STEEL	316 STAINLESS STEEL
4	1	LOWER SHAFT O-RING	BUNA-N (non-wetted part)	EPDM, VITON®
5	1	SEAT	BUNA-N	EPDM, VITON®, EPDM BACKED PTFE
6	1	BODY	DUCTILE IRON	316 STAINLESS STEEL
7	1	LOWER BUSHING	PTFE	LUBRICATED BRONZE
8	1	UPPER SHAFT	420 STAINLESS STEEL	431 STAINLESS STEEL, 17-4 PH®
9	1	SHAFT KEEPER RING	STEEL	
10	2	UPPER BUSHING	PTFE	LUBRICATED BRONZE
11	1	UPPER SHAFT O-RING	BUNA-N (non-wetted part)	EPDM, VITON®
12	1	RETAINING RING	STEEL	

### Butterfly Valve Cv Values (US-GPM @ 1 Δ P) - Rated Flow Coefficients

Valve Size	10°	20°	30°	40°	50°	60°	70°	80°	90°
1-1/2"	NA	4	7	11	19	29	44	57	70
2"	0.9	6	12	22	38	59	93	125	155
2-1/2"	1.5	10	21	38	61	97	152	213	262
3"	2	14	31	55	91	145	245	340	417
4"	3	24	55	100	163	261	444	640	773
5"	5	39	88	160	261	421	716	1,053	1,267
6"	8	54	120	224	369	521	1,020	1,500	1,771
8"	13	99	226	421	698	1,125	1,862	2,789	3,230
10"	21	162	366	686	1,135	1,826	3,044	4,471	5,327
12"	28	240	542	1,026	1,687	2,739	4,563	6,832	8,117
14"	39	286	689	1,308	2,081	3,187	5,460	8,804	10,878
16"	53	429	995	1,887	2,954	4,659	7,907	11,854	14,062
18"	69	557	1,292	2,436	3,786	6,005	10,440	14,457	17,884
20"	86	689	1,622	2,916	4,738	7,223	12,537	18,573	22,484
24"	241	1,016	2,368	4,095	6,783	10,574	17,132	25,462	31,320

### Approximate Operating Torque (In·lbs)

SIZE	Δ P= 50 PSI		Δ P= 100 PSI		Δ P= 150 PSI	
	WET	DRY & PTFE	WET	DRY & PTFE	WET	DRY & PTFE
1-1/2"	91	145	96	153	103	163
2"	109	174	115	184	123	196
2-1/2"	115	218	122	231	136	258
3"	175	332	186	353	192	364
4"	276	505	309	565	328	600
5"	433	753	476	828	512	890
6"	672	1,182	748	1,316	831	1,462
8"	1,214	2,088	1,360	2,339	1,527	2,626
10"	1,902	3,233	2,200	3,740	2,530	4,310
12"	2,781	4,533	3,284	5,353	3,794	6,184
14"	3,548	5,322	4,125	6,187	4,870	7,305
16"	4,415	6,622	5,590	8,385	6,685	10,027
18"	5,780	8,670	7,354	11,031	8,958	13,437
20"	7,410	11,115	9,670	14,505	11,950	17,925
24"	11,580	17,370	14,860	22,290	18,680	28,020

### UNDERCUT DISC OPERATING TORQUE (In·lbs)

Size	50 PSID		75 PSID	
	WET	DRY & PTFE	WET	DRY & PTFE
6"	403	709	426	749
8"	728	1,253	772	1,328
10"	1,141	1,940	1,231	2,092
12"	1,669	2,720	1,820	2,966

PTFE Seats: Use Dry Operating Torque Only.

### Seat Temperature Ratings

Material	Temperature Ratings °F
Buna-N	0° to 200°
EPDM	-20° to 250°
Food Grade EPDM	-20° to 250°
High Temp EPDM	-20° to 275°
PTFE over EPDM	0° to 275°
Viton®	-10° to 325°

### Wafer Style Body

### Lug Style Body

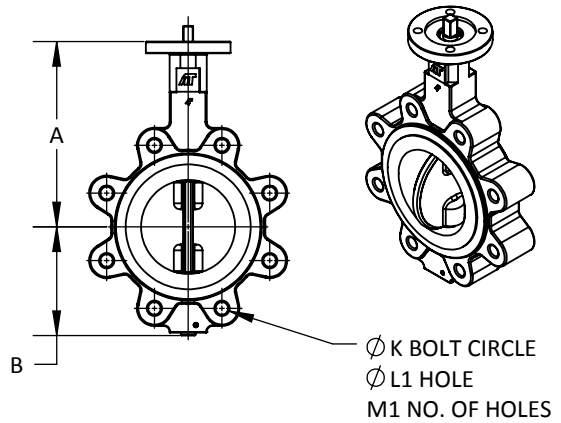
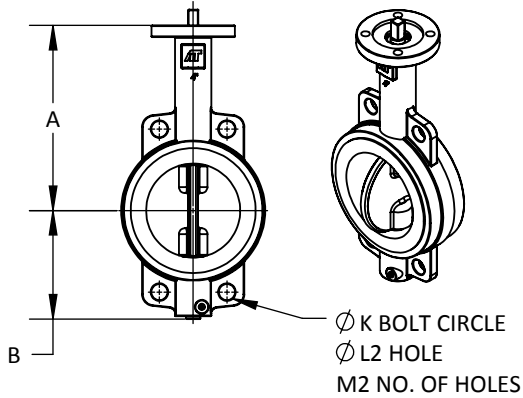
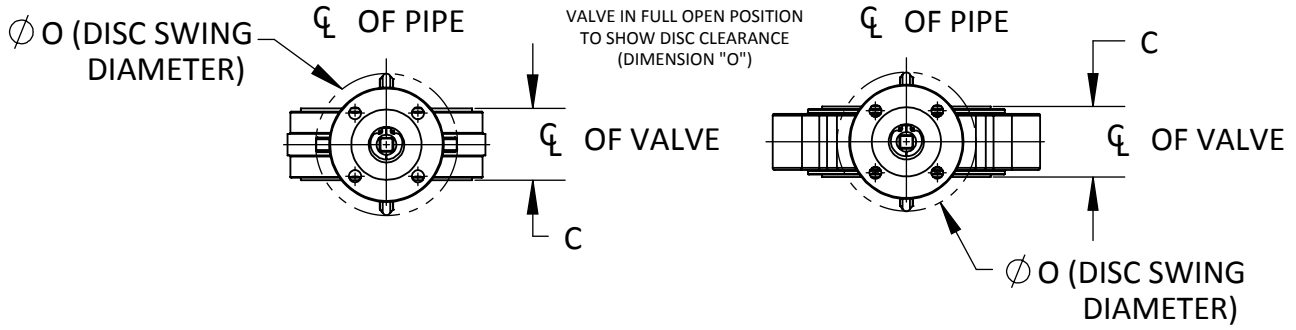

### Mounting Pad Details

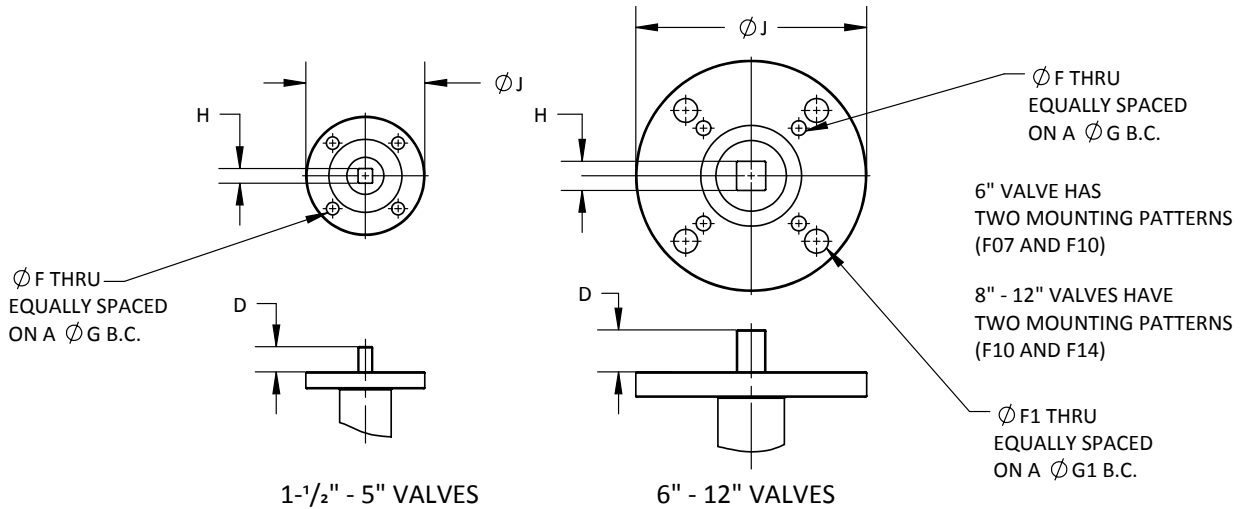

SIZE	A	B	C	D	F	F1	G	G1	H	J	K	L1	L2	M1	M2	WAFER	LUG	O	ISO5211
1-1/2"	5.35	2.72	1.26	0.67	0.38	N/A	2.756	N/A	0.354	3.54	3.88	1/2-13 UNC	0.63	4	4	5 LBS	8 LBS	1.68	F07
2"	6.38	3.13	1.75	0.73	0.38	N/A	2.756	N/A	0.354	3.54	4.75	5/8-11 UNC	0.75	4	4	6 LBS	9 LBS	2.00	F07
2-1/2"	6.88	3.50	1.94	0.73	0.38	N/A	2.756	N/A	0.354	3.54	5.50	5/8-11 UNC	0.75	4	4	7 LBS	13 LBS	2.50	F07
3"	7.13	3.75	1.94	0.73	0.38	N/A	2.756	N/A	0.354	3.54	6.00	5/8-11 UNC	0.75	4	4	10 LBS	14 LBS	3.10	F07
4"	7.88	4.64	2.13	0.77	0.38	N/A	2.756	N/A	0.433	3.54	7.50	5/8-11 UNC	0.75	8	4	13 LBS	19 LBS	4.10	F07
5"	8.38	5.00	2.34	0.85	0.38	N/A	2.756	N/A	0.551	3.54	8.50	3/4-10 UNC	0.88	8	4	18 LBS	22 LBS	4.85	F07
6"	8.88	5.50	2.25	0.85	0.38	0.44	2.756	4.016	0.551	4.92	9.50	3/4-10 UNC	0.88	8	4	21 LBS	31 LBS	6.12	F07/F10
8"	10.25	6.88	2.50	0.83	0.44	0.71	4.016	5.512	0.669	6.88	11.75	3/4-10 UNC	0.88	8	4	34 LBS	49 LBS	7.96	F10/F14
10"	11.50	8.00	2.85	1.02	0.44	0.71	4.016	5.512	0.748	6.88	14.25	7/8-9 UNC	1.00	12	4	45 LBS	72 LBS	9.86	F10/F14
12"	13.25	9.50	3.22	1.32	0.44	0.71	4.016	5.512	0.866	6.88	17.00	7/8-9 UNC	1.00	12	4	74 LBS	105 LBS	11.88	F10/F14

DIMENSION "C" REPRESENTS VALVE SEAT IN RELAXED CONDITION. APPROXIMATELY 1/8" OF TOTAL COMPRESSION IS REQUIRED FOR PROPER SEALING WITH PIPE FLANGES.

A-T Controls reserves the right to change product designs and technical/dimensional specifications without notice. See website for updates.

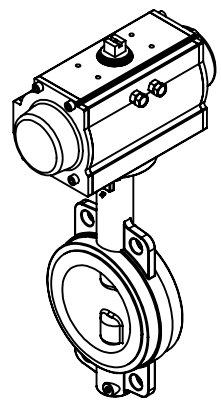
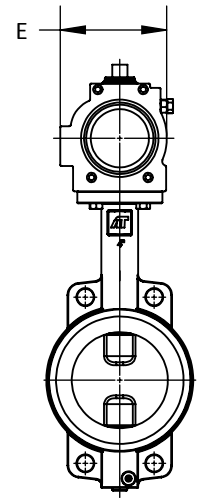
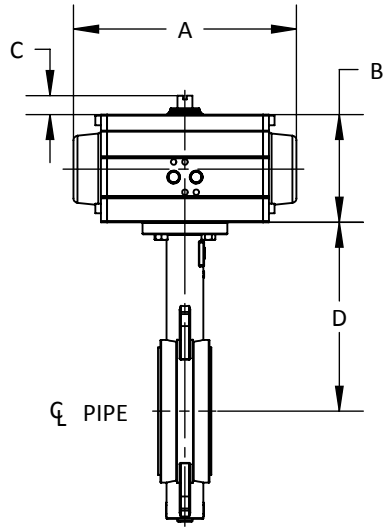

OC/OS Series Double Acting Dimensions

SELECT "WET" OR "DRY" MEDIUM APPLICATION AND THE CORRESPONDING PRESSURE DROP VALUE. THEN SELECT THE VALVE SIZE AND REFERENCE THE CORRECT ACTUATOR DIMENSION SET BELOW. *PTFE Seats: Use Dry Actuator Sizing Only.*

VALVE SIZE	WET			DRY & PTFE		
	PRESSURE DROP					
	50	100	150	50	100	150
ACTUATOR DIMENSION SET						
	#	#	#	#	#	#
1-1/2"	#	#	#	#	#	#
2"	1	1	1	1	1	1
2-1/2"	2	2	2	2	2	2
3"	3	3	3	14	14	14
4"	4	5	5	5	5	5
5"	6	6	6	15	15	15
6"	7	7	7	16	16	17
8"	8	9	9	9	18	18
10"	10	11	11	19	19	19
12"	12	12	13	13	13	13

DIMENSION SET	A	B	C	D	E	ACTUATOR
#	7.95	3.43	0.79	5.35	3.29	2R40DA
1	7.95	3.43	0.79	6.34	3.29	2R40DA
2	7.95	3.43	0.79	6.89	3.29	2R40DA
3	7.95	3.43	0.79	7.13	3.29	2R40DA
4	7.95	3.43	0.79	7.87	3.29	2R40DA
5	9.29	4.49	0.79	7.87	4.41	2R80DA
6	9.29	4.49	0.79	8.39	4.41	2R80DA
7	10.87	4.88	0.79	8.90	4.69	2R130DA
8	11.46	5.28	0.79	10.24	5.06	2R200DA
9	13.90	6.18	0.79	10.24	5.91	2R300DA
10	13.90	6.18	0.79	11.50	5.91	2R300DA
11	15.16	6.93	1.18	11.50	6.50	2R500DA
12	15.16	6.93	1.18	13.27	6.50	2R500DA
13	20.95	8.31	1.18	13.27	6.89	2R850DA
14	9.29	4.49	0.79	7.13	4.41	2R80DA
15	10.87	4.88	0.79	8.39	4.69	2R130DA
16	11.46	5.28	0.79	8.90	5.06	2R200DA
17	13.90	6.18	0.79	8.90	5.91	2R300DA
18	15.16	6.93	1.18	10.24	6.50	2R500DA
19	20.95	8.31	1.18	11.50	6.89	2R850DA

Pneumatic Double Acting actuators above are sized with 80 PSIG supply.

CONSULT FACTORY FOR ACTUATOR SIZING ON VALVES LARGER THAN 12"

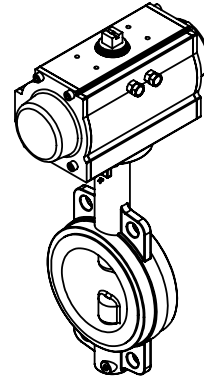
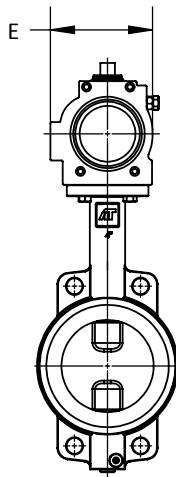
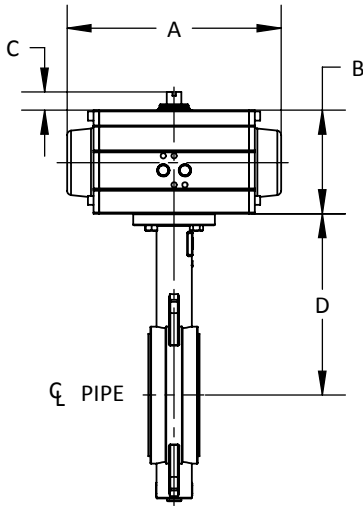

SELECT "WET" OR "DRY" MEDIUM APPLICATION AND THE CORRESPONDING PRESSURE DROP VALUE. THEN SELECT THE VALVE SIZE AND REFERENCE THE CORRECT ACTUATOR DIMENSION SET BELOW. *PTFE Seats: Use Dry Actuator Sizing Only.*

VALVE SIZE	WET			DRY & PTFE		
	PRESSURE DROP					
	50	100	150	50	100	150
	ACTUATOR DIMENSION SET					
1-1/2"	#	#	#	#	#	#
2"	1	1	1	1	1	1
2-1/2"	2	2	2	2	2	13
3"	3	3	3	14	15	15
4"	4	4	4	16	16	16
5"	5	5	5	5	5	5
6"	6	6	6	17	17	18
8"	7	7	8	19	19	19
10"	9	10	10	20	CF	CF
12"	11	12	12	CF	CF	CF

DIMENSION SET	A	B	C	D	E	ACTUATOR
#	9.29	4.49	0.79	5.35	4.41	2R80SR
1	9.29	4.49	0.79	6.34	4.41	2R80SR
2	9.29	4.49	0.79	6.89	4.41	2R80SR
3	9.29	4.49	0.79	7.13	4.41	2R80SR
4	11.46	5.28	0.79	7.87	5.06	2R200SR
5	13.90	6.18	0.79	8.39	5.91	2R300SR
6	13.90	6.18	0.79	8.90	5.91	2R300SR
7	15.16	6.93	1.18	10.24	6.50	2R500SR
8	20.95	8.31	1.18	10.24	6.89	2R850SR
9	20.95	8.31	1.18	11.50	6.89	2R850SR
10	22.68	9.17	1.18	11.50	7.60	2R1200SR
11	22.68	9.17	1.18	13.27	7.60	2R1200SR
12	24.37	10.12	1.18	13.27	8.31	2R1750SR
13	10.87	4.88	0.79	6.89	4.69	2R130SR
14	10.87	4.88	0.79	7.13	4.69	2R130SR
15	11.46	5.28	0.79	7.13	5.06	2R200SR
16	13.90	6.18	0.79	7.87	5.91	2R300SR
17	15.16	6.93	1.18	8.90	6.50	2R500SR
18	20.95	8.31	1.18	8.90	6.89	2R850SR
19	22.68	9.17	1.18	10.24	7.60	2R1200SR
20	24.37	10.12	1.18	11.50	8.31	2R1750SR

Pneumatic Spring Return actuators above are sized with 5 springs per side, fail close.

CONSULT FACTORY FOR ACTUATOR SIZING ON VALVES LARGER THAN 12"

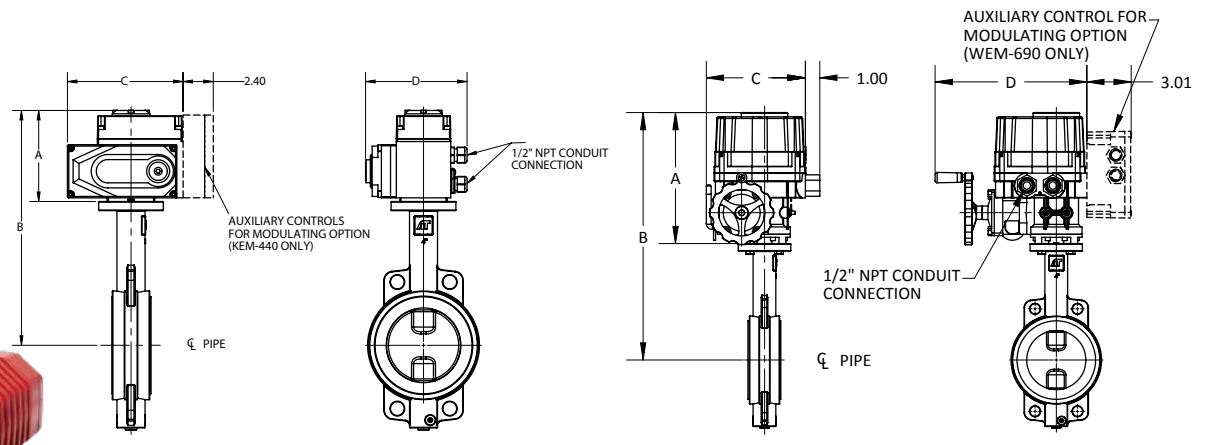

SELECT "WET" OR "DRY" MEDIUM APPLICATION AND THE CORRESPONDING PRESSURE DROP VALUE. THEN SELECT THE VALVE SIZE AND REFERENCE THE CORRECT ACTUATOR DIMENSION SET BELOW. *PTFE Seats: Use Dry Actuator Sizing Only.*

VALVE SIZE	WET			DRY & PTFE		
	PRESSURE DROP					
	50	100	150	50	100	150
ACTUATOR DIMENSION SET						
	#	#	#	#	#	#
1-1/2"	#	#	#	#	#	#
2"	1	1	1	1	1	1
2-1/2"	2	2	2	2	2	2
3"	3	3	3	3	3	3
4"	4	4	4	12	12	12
5"	6	6	6	13	13	13
6"	7	7	7	7	7	14
8"	8	9	9	15	15	15
10"	10	10	10	16	16	16
12"	11	11	11	17	18	18

DIMENSION SET	A	B	C	D	ACTUATOR
#	5.14	10.49	6.46	5.47	KE-440*
1	5.14	11.47	6.46	5.47	KE-440*
2	5.14	12.02	6.46	5.47	KE-440*
3	5.14	12.26	6.46	5.47	KE-440*
4	5.31	13.18	7.37	6.30	KE-880*
6	8.66	17.04	6.69	10.16	WE-690
7	10.24	19.13	9.02	13.31	WE-1350
8	10.24	20.47	9.02	13.31	WE-1350
9	10.24	20.47	9.02	13.31	WE-1700
10	11.42	22.91	10.20	14.49	WE-2640
11	11.42	24.68	10.20	14.49	WE-4400
12	8.66	16.53	6.69	10.16	WE-690
13	10.24	18.62	9.02	13.31	WE-1350
14	10.24	19.13	9.02	13.31	WE-1700
15	11.42	21.65	10.20	14.49	WE-2640
16	11.42	22.91	10.20	14.49	WE-4400
17	11.42	24.68	10.20	14.49	WE-5200
18	12.40	25.66	11.69	16.14	WE-6900

CONSULT FACTORY FOR ACTUATOR SIZING ON VALVES LARGER THAN 12"  
 \*KE Series actuator recommended; WE-500 may be substituted



## Gear Operator

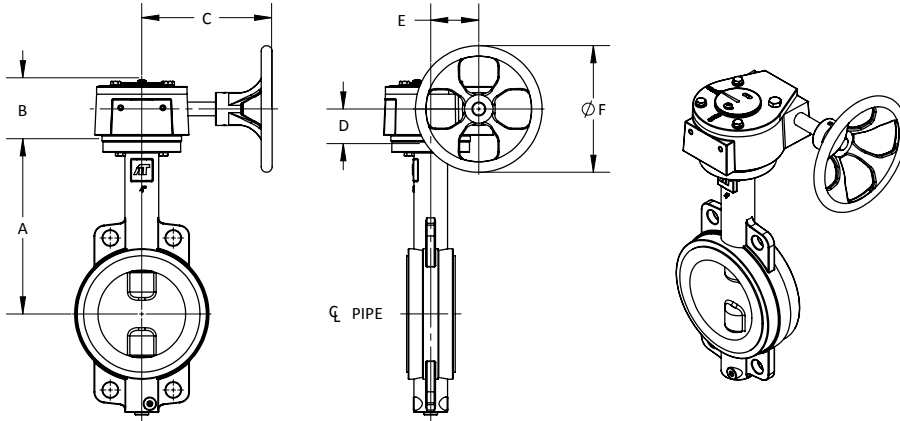

SIZE	A	B	C	D	E	F
1-1/2"	5.35	2.79	6.00	1.48	1.77	5.87
2"	6.38	2.79	6.00	1.48	1.77	5.87
2-1/2"	6.88	2.79	6.00	1.48	1.77	5.87
3"	7.13	2.79	6.00	1.48	1.77	5.87
4"	7.88	2.79	6.00	1.48	1.77	5.87
5"	8.38	2.79	6.00	1.48	1.77	5.87
6"	8.88	2.79	6.00	1.48	1.77	5.87
8"	10.25	3.30	8.75	1.57	2.60	11.62
10"	11.50	3.30	8.75	1.57	2.60	11.62
12"	13.25	3.30	8.75	1.57	3.01	11.62

CONSULT FACTORY FOR GEAR ACTUATOR SIZING ON VALVES LARGER THAN 12"

## Hand Lever

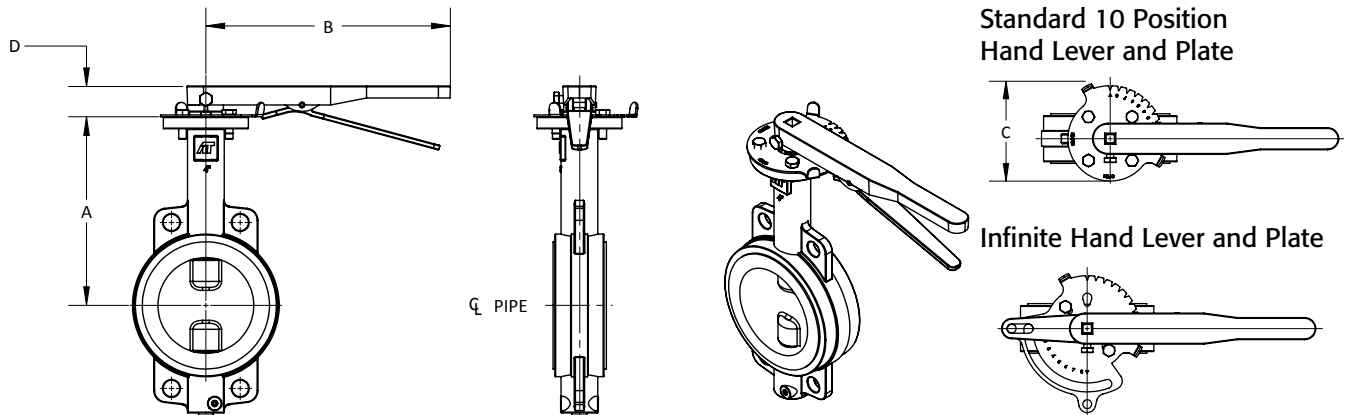

SIZE	A	B	C	D
1-1/2"	5.35	10.51	4.45	1.18
2"	6.38	10.51	4.45	1.18
2-1/2"	6.88	10.51	4.45	1.18
3"	7.13	10.51	4.45	1.18
4"	7.88	10.51	4.45	1.18
5"	8.38	10.51	4.45	1.18
6"	8.88	10.51	4.45	1.18
8"	10.25	14.13	6.63	1.32
10"	11.50	14.13	6.63	1.32
12"	13.25	20.75	6.63	1.44



## Part Number Matrix for A-T Controls Resilient Seated Butterfly Valves

1 Valve Series	
OC	A-T BFV with DD Stem (14" and larger)
OS	A-T BFV with Square Stem (2-12") (Standard)

2 Body Material	
blank	(No Designation)= Stainless Steel (SST) Body
B	Ductile Iron (Standard)

3 End Connection	
L1	125/150# Lug
W1	125/150# Wafer with Guide Holes
W2	125/150# Wafer (no Guide Holes)

4 Valve Size			
0150	1-1/2"	1400	14"
0200	2"	1600	16"
0250	2-1/2"	1800	18"
0300	3"	2000	20"
0400	4"	2400	24"
0500	5"	3000	30"
0600	6"	3600	36"
0800	8"		
1000	10"		
1200	12"		

5 Seat Material/Style			
B	Buna	P	PTFE
E	EPDM	V	Viton®
H	High Temp EPDM		
F	Food Grade (FDA compliant) EPDM		(up to 12" only)

6 Disc Material/Style	
B	Aluminum Bronze
D	Ductile Iron (Nickel Plated)
N	Nylon Coated Ductile Iron
S	316 SST
U	Undercut Aluminum Bronze (6" and larger only)
W	Polished 316 SST
Y	Undercut Polished 316 SST (6" and larger only)
Z	Undercut 316 SST (6" and larger only)

7 Stem Bushing	
R	PTFE (Standard)
B	Lubricated Bronze

8 Operator Designation	
X	Bare Stem
H	Standard 10 point Handle
S	Stainless Steel 10 point Handle
I	Infinite Adjustment Handle
G	Gear Operator

9 Stem	
E	420 SST Upper and Lower Stem (Standard)
F	431 SST Upper Stem, 316 SST Lower Stem (Standard with PTFE seat)
A	17-4 PH® Upper stem, 316 SST Lower Stem

PTFE seat: F or A stem options only

HOW TO ORDER MANUAL RESILIENT SEATED BUTTERFLY VALVES								
1	2	-	3	-	4	-	5	6 7 - 8 9
↓↓	↓		↓		↓		↓↓↓	↓ ↓
OSB	-	W1	-	0200	-	EDR	-	X E

HOW TO ORDER AUTOMATED RESILIENT SEATED BUTTERFLY VALVES										
1	2	-	3	-	4	-	5	6 7 - 8 9 / actuator size - options		
↓ ↓	↓		↓		↓		↓ ↓ ↓	↓ ↓	↓	↓
OSB	-	W1	-	0200	-	E D R	-	X E /	2R3S	- XX
(see Actuator Size Legend)										

## AS Series Lined Resilient Seated Butterfly Valves

1 Valve Series	
AS	A-T Split Body Lined Butterfly Valve
2 Body Material	
blank	(No Designation) Stainless Steel (SST) Body
C	Carbon Steel (ASTM A216 Grade WCB)
3 End Connection	
L1	125/150# Lug
W1	125/150# Wafer
4 Valve Size	
0150	1-1/2" 1400 14"
0200	2" 1600 16"
0250	2-1/2" 1800 18"
0300	3" 2000 20"
0400	4" 2400 24"
0500	5"
0600	6"
0800	8"
1000	10"
1200	12"
5 Seat Material/Style	
P	PTFE
6 Disc Material/Style	
F	PFA Encapsulated over 304 SST (standard with WCB body)
M	PFA Encapsulated over 316 SST (standard with SST body)
7 Stem Bushing	
R	PTFE
8 Operator Designation	
X	Bare Stem
H	Standard 10 point Handle
S	Stainless Steel 10 point Handle
G	Gear Operator
9 Stem	
A	17-4 PH® Stem

EXAMPLE:  
ASC-L1-0600-PFR-XA  
(6" A-T Controls Split Body Lined Butterfly Valve, ASTM A216 Grade WCB Body, 150# Lug Style, PTFE Seat, PFA Encapsulated over 304 SST Disc, PTFE Stem Bushing, 17-4 PH Stem.)