



This 3-way ball valve offers diverting and mixing flow patterns, often eliminating the need for two valves. The full port design is easily automated and is available with various seat materials. The bolts on side flanges make for easy seat changes as necessary to accommodate your service. Available in L or T port configurations.

Cv Values

VALVE SIZE	T-PORT STRAIGHT THRU	L & T-PORT 90°
1-1/2"	213	54
2"	312	90
2-1/2"	688	159
3"	886	211
4"	1,891	386
6"	5,834	926

Class 150 Torque Values for RTFE Seats		
VALVE SIZE	BREAK IN* LBS.	RUN IN* LBS.
1-1/2"	449	224
2"	715	518
2-1/2"	1,606	736
3"	2,527	1,258
4"	2,834	1,905
6"	4,405	2,500

NOTE: For other seat material, consult factory

FLOW PATTERNS

3-Way L-Port

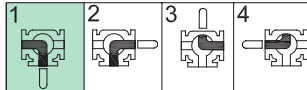

3-Way T-Port

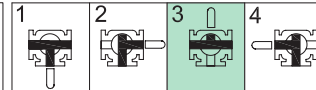

Shaded boxes indicate standard flow path from factory unless otherwise specified by customer. Automated assemblies rotate counter-clockwise standard from the factory when energized. For L-Ports that would be L1 to L2 and T3 to T4 for T-ports. By specifying FCCW or DAR actuators, multiple flow patterns can be achieved to meet process requirements.

Easy to Automate!

See automated data sheets for pre-sized assemblies



Pneumatic



Electric



**Series 31
3-Way Flanged
Direct Mount
Ball Valve**

Sizes 1-1/2" thru 6"

316SST or WCB

Full Port Design

ANSI Class 150

1-pc Ball & Stem

Blowout Proof Stem

RTFE Seats Standard

"L" or "T" Port Option

Trunnion Ball Design

Lockable Manual Handle

ISO 5211 Actuator Mounting Pad

STANDARDS

Design ANSI/ASME B16.34
 Flanged Ends ANSI/ASME B16.5
 Face-to-Face (per factory's standard)
 Pressure Testing API 598
 Mounting ISO 5211
 Safety Integrity IEC 61508:2010; SIL 3
 Marking System for Valves MSS SP-25
 Material Certification EN 10204-3.1 MTR
 Quality Assurance ISO 9001:2015



**HOW TO ORDER
MANUAL VALVES**

SAMPLE PART #

31C-F1-0150-XXX-*

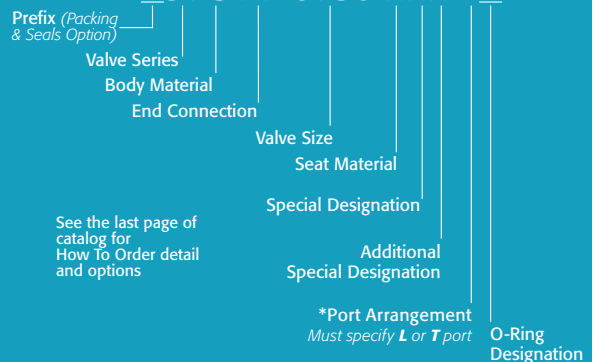

See the last page of catalog for How To Order detail and options

Refer to Series 31 IOM for all repair kit, seat and gasket part numbers.

See Part Number Matrix for itemized options



9955 International Blvd.
 Cincinnati, Ohio 45246
 www.atcontrols.com

PHONE (513) 247-5465
 FAX (513) 247-5462
 sales@atcontrols.com

Series 31

3-Way Flanged Ball Valve Full Port, L or T Option ANSI Class 150

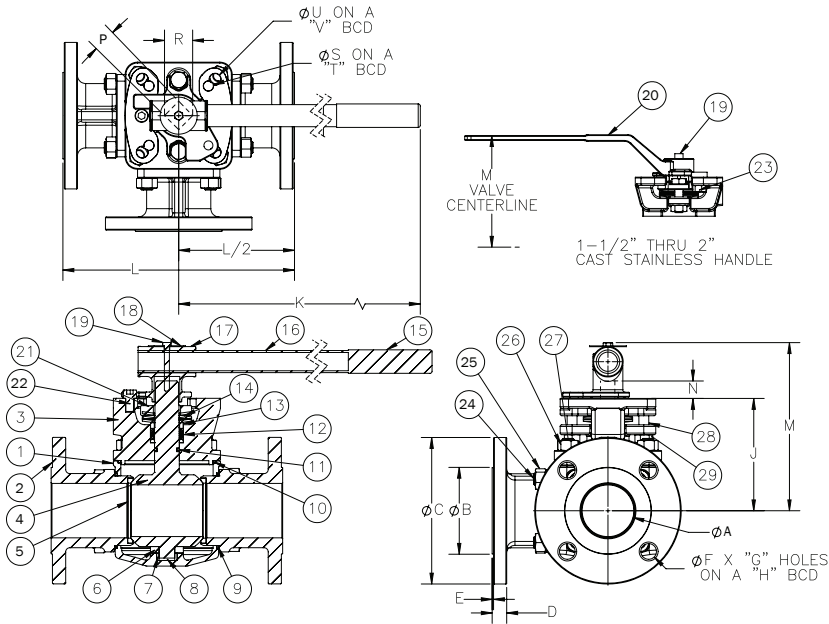

Pressure vs. Temperature Chart
for Class 150 Flanged Valves 1-1/2" to 6"

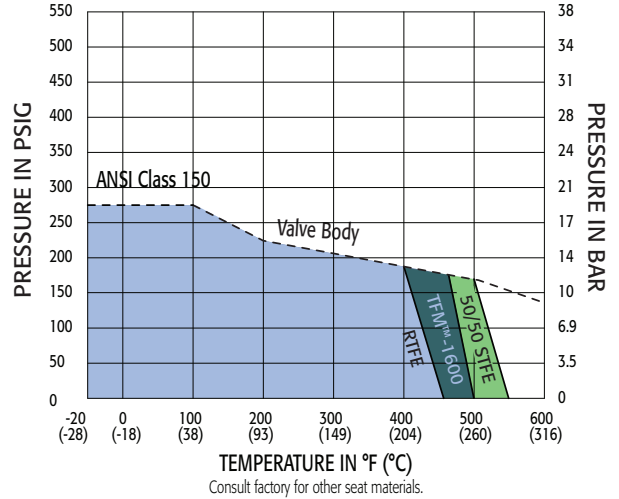

NOTE: Dotted line shows the rating for the valve body. Solid lines show the rating of the seat material. Both ratings need to be considered when determining the limitation of a valve for a specific application.

For temperatures over 400°F the PTFE components (body gasket, joint gasket, stem packing) along with the FKM O-ring must be replaced. TFM™-1600 (body gasket, joint gasket, stem packing) and FFKM (Perfluoroelastomer) can be used to 500°F. Grafoil (body gasket, joint gasket, stem packing) and FFKM (Perfluoroelastomer) can be used to 550°F.

For specific high or low temperature applications along with a specific chemical application please contact A-T Controls for additional assistance.

MATERIALS LIST

NO.	PART NAME	QTY	STAINLESS STEEL	CARBON STEEL	SPARE PART
1	BODY	1	ASTM A351 GRADE CF8M	ASTM A216 GRADE WCB	
2	END CAP	3	ASTM A351 GRADE CF8M	ASTM A216 GRADE WCB	
3	TOP COVER	1	ASTM A351 GRADE CF8M	ASTM A216 GRADE WCB	
4	BALL & STEM	1	ASTM A351 GRADE CF8M	ASTM A351 GRADE CF8M	
5	SEAT	3	RTFE	RTFE	*
6	THRUST WASHER	1	50/50 STFE	50/50 STFE	*
7	TRUNNION BEARING	1	PEEK	PEEK	*
8	ANTI-STATIC SPRING	1	AISI 316	AISI 316	*
9	JOINT GASKET	3	PTFE	PTFE	*
10	COVER GASKET	1	PTFE	PTFE	*
11	STEM O-RING	1	FKM	FKM	*
12	GLAND PACKING	1 SET	PTFE	PTFE	*
13	GLAND BUSHING	1	AISI 304	AISI 304	
14	BELLEVILLE WASHER	3 *	AISI 301	AISI 301	
15	HANDLE SLEEVE	1	VINYL	VINYL	
16	HANDLE BAR 2-1/2" -3"	1	AISI 304	AISI 304	
16	HANDLE BAR -4"-6"	1	CARBON STEEL	CARBON STEEL	
17	HANDLE HUB 2-1/2" -4"	1	ASTM A351 GRADE CF8	ASTM A351 GRADE CF8	
17	HANDLE HUB-6"	1	WCB	WCB	
18	INDICATOR PLATE	1	AISI 304	AISI 304	
19	HANDLE BOLT	1	AISI 304	AISI 304	
20	HANDLE 1-1/2" - 2"	1	AISI 304	AISI 304	
21	PACKING GLAND	1	ASTM A351 GRADE CF8	ASTM A351 GRADE CF8	
22	HANDLE STOP BOLT	1	AISI 304	AISI 304	
23	NUT & WASHER	1	AISI 304	AISI 304	
24	BODY STUD	#	ASTM A193 GRADE B8	ASTM A193 GRADE B8	
25	BODY NUT	#	ASTM A194 GRADE 8	ASTM A194 GRADE 8	
26	COVER STUD	^	ASTM A193 GRADE B8	ASTM A193 GRADE B8	
27	COVER STUD	^	ASTM A194 GRADE 8	ASTM A194 GRADE 8	
28	PACKING GLAND BOLT	2	AISI 304	AISI 304	
29	PACKING GLAND NUT	2	AISI 304	AISI 304	

* On 6" valve, qty is 8 pcs (4 on each packing gland bolt)
1-1/2" THRU 3" = Qty. 12 pcs | 4" = Qty. 18 pcs | 6" = Qty. 30 pcs
^ 1-1/2" THRU 3" = 4 pcs, 4" = 6 pcs, 6" = 12 pcs

TEMPERATURE CHART for Stem Packing, Gasket & O-Rings

COMPONENT	MATERIAL	TEMPERATURE
Stem Packing & Gaskets	PTFE	-50 to 400°F
	TFM™-1600	-75 to 500°F
	GRAFOIL	-100 to 1100°F
O-Rings	FKM	-20 to 400°F
	FFKM KALREZ® 4079	+30 to 600°F

DIMENSIONS For ANSI Class 150 (IN)

SIZE	VALVE DIMENSIONS											
	A	B	C	D	E	F	G	H	J	K	L	M
1-1/2"	1.57	2.88	5.00	0.56	0.06	0.63	4	3.88	4.13	10.31	7.20	6.16
2"	1.97	3.62	6.00	0.63	0.06	0.75	4	4.75	4.45	10.31	8.66	6.42
2-1/2"	2.60	4.12	7.00	0.69	0.06	0.75	4	5.50	5.37	14.37	11.06	8.07
3"	2.99	5.00	7.50	0.75	0.06	0.75	4	6.00	5.78	19.88	11.22	8.46
4"	3.98	6.19	9.00	0.94	0.06	0.75	8	7.50	7.52	27.76	13.70	11.06
6"	5.91	8.50	11.00	1.00	0.06	0.87	8	9.50	9.80	37.60	18.90	13.77

ACTUATOR MOUNTING DIMENSIONS

SIZE	N	P	R	S	T	U	V	ISO 5211	(LBS)
1-1/2"	0.75	0.748	0.93	0.39	2.756	0.47	4.016	F07/F10	25
2"	0.75	0.748	0.93	0.39	2.756	0.47	4.016	F07/F10	37
2-1/2"	0.83	0.866	1.10	0.47	4.016	0.55	4.921	F10/F12	58
3"	0.83	0.866	1.10	0.47	4.016	0.55	4.921	F10/F12	79
4"	1.14	1.063	1.38	0.55	4.921	0.71	5.512	F12/F14	129
6"	1.50	1.417	1.81	0.71	5.512	0.87	6.496	F14/F16	289



Pneumatic Double Acting

Automated Ball Valve Package

Series 31 3-Way Flanged Ball Valve

- Sizes 1-1/2"-6"
- 316SST or WCB
- ANSI Class 150
- Full Port Design
- 1-pc Ball & Stem
- Blowout Proof Stem
- RTFE Seats Standard
- "L" or "T" Port Option
- Trunnion Ball Design
- ISO 5211 Actuator Mounting Pad

STANDARDS

Design	ANSI/ASME B16.34
Flanged Ends	ANSI/ASME B16.5
Face-to-Face	(per factory's standard)
Pressure Testing	API 598
Mounting	ISO 5211
Safety Integrity	IEC 61508:2010; SIL 3
Marking System for Valves	MSS SP-25
Material Certification	EN 10204-3.1 MTR
Quality Assurance	ISO 9001:2015



Flanged 3-Way

For operating temperatures in excess of 175° F with Buna-N seals in the actuator, an extended bracket is required. FKM seals in the actuator require an extended bracket for more than 300° F. Please consult factory for sizing information.

Class 150 Double Acting Assembly DIMENSIONS (IN)

VALVE SIZE	A	B	C	D	E
1-1/2"	9.29	9.66	7.20	4.41	5.00
2"	10.87	10.38	8.66	4.83	6.00
2-1/2"	13.90	13.06	11.06	6.05	7.00
3"	15.16	14.22	11.22	6.69	7.50
4"	15.16	15.96	13.70	6.69	9.00
6"	22.68	20.27	18.90	8.42	11.00

DIMENSIONS SHOWN ARE FOR ASSEMBLIES SIZED FOR 80 PSI SUPPLY

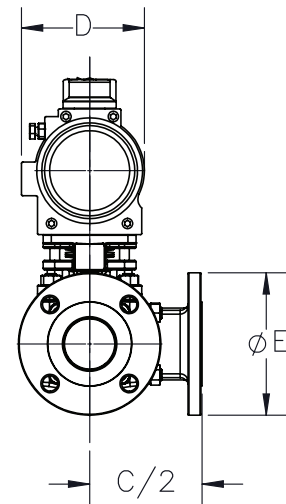
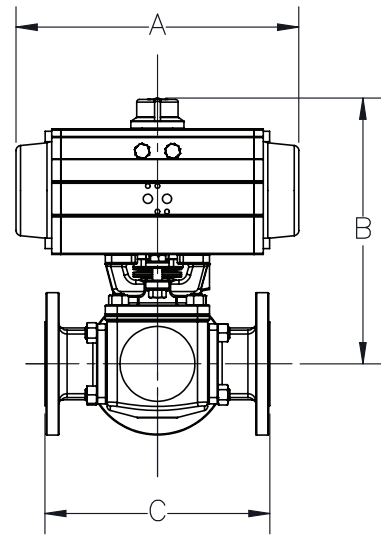

SERIES 31 3-Way 150# Flanged Direct Mount

SIZED FOR 80 psi AIR SUPPLY	
SIZE	MODEL
1-1/2"	31-FX-150/2R3D-XX-*
2"	31-FX-200/2R4D-XX-*
2-1/2"	31-FX-250/2R6D-XX-*
3"	31-FX-300/2R7D-XX-*
4"	31-FX-400/2R7D-XX-*
6"	31-FX-600/2R9D-XX-*

SIZED FOR 60 psi AIR SUPPLY	
SIZE	MODEL
1-1/2"	31-FX-150/2R4D-XX-*
2"	31-FX-200/2R5D-XX-*
2-1/2"	31-FX-250/2R6D-XX-*
3"	31-FX-300/2R8D-XX-*
4"	31-FX-400/2R8D-XX-*
6"	31-FX-600/2R9D-XX-*

* Must specify L or T port

Actuators are sized for clean liquid surface with a specific gravity of 1 and at 70° F.

OPTIONS

DESCRIPTION	PART NO. SUFFIX	DESCRIPTION	PART NO. SUFFIX
Type 4 Solenoid	(A)	Type 4 Limit Switch (2) spdt	(A)
Type 7 Solenoid	(B)	Type 7 Limit Switch (2) spdt	(B)
Intrinsically Safe Solenoid	(C)	Intrinsically Safe Limit Switch	(C)

Other options available - call for details
Actuators are sized based on clean/clear fluid.

SAMPLE PART #
31C-FX-150/2R3D-XX-*

Prefix (Packing & Seals Option) | Valve Series | Carbon Steel | End Connection | Seat Material | Valve Size | TRIAC Actuator Series | Actuator Size | Double Acting | Solenoid | Limit Switch | Port Arrangement | O-Ring Designation

See the last page of catalog for How To Order detail and options

* Must specify L or T port

Refer to Series 31 IOM for all repair kit, seat and gasket part numbers.

See Automated Part Number Matrix for complete part number and options.



9955 International Blvd.
Cincinnati, Ohio 45246
www.atcontrols.com

PHONE (513) 247-5465
FAX (513) 247-5462
sales@atcontrols.com



Pneumatic Spring Return

Automated Ball Valve Package

Series 31 3-Way Flanged Ball Valve

- Sizes 1-1/2"-6"
- 316SST or WCB
- ANSI Class 150
- Full Port Design
- 1-pc Ball & Stem
- Blowout Proof Stem
- RTFE Seats Standard
- "L" or "T" Port Option
- Trunnion Ball Design
- ISO 5211 Actuator Mounting Pad

STANDARDS

Design	ANSI/ASME B16.34
Flanged Ends	ANSI/ASME B16.5
Face-to-Face	(per factory's standard)
Pressure Testing	API 598
Mounting	ISO 5211
Safety Integrity	IEC 61508:2010; SIL 3
Marking System for Valves	MSS SP-25
Material Certification	EN 10204-3.1 MTR
Quality Assurance	ISO 9001:2015



Flanged 3-Way

For operating temperatures in excess of 175° F with Buna-N seals in the actuator, an extended bracket is required. FKM seals in the actuator require an extended bracket for more than 300° F. Please consult factory for sizing information.

Class 150 Spring Return Assembly DIMENSIONS (IN)

VALVE SIZE	A	B	C	D	E
1-1/2"	11.46	10.45	7.20	5.19	5.00
2"	13.90	12.14	8.66	6.05	6.00
2-1/2"	13.90	13.47	11.06	6.05	7.00
3"	20.95	15.60	11.22	7.64	7.50
4"	22.68	18.18	13.70	8.42	9.00
6"	24.37	21.22	18.90	9.29	11.00

DIMENSIONS SHOWN ARE FOR ASSEMBLIES SIZED FOR 80 PSI SUPPLY

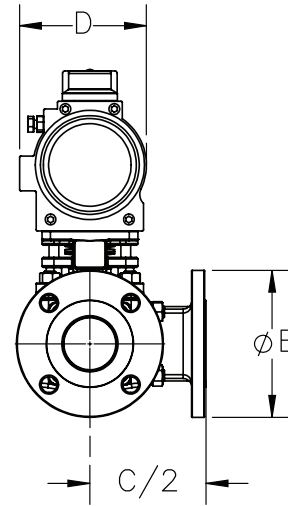
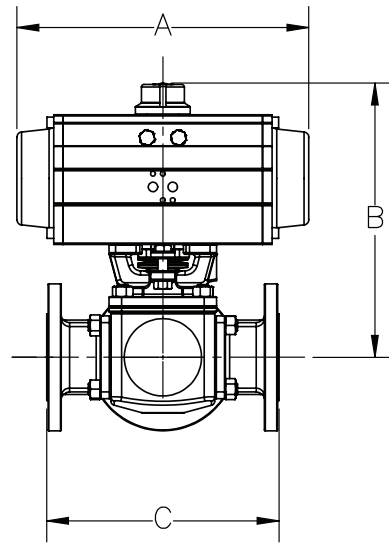

SERIES 31 3-Way 150# Flanged Direct Mount

SIZED FOR 80 psi AIR SUPPLY	
SIZE	MODEL
1-1/2"	31-FX-150/2R5S-XX-*
2"	31-FX-200/2R6S-XX-*
2-1/2"	31-FX-250/2R6S-XX-*
3"	31-FX-300/2R8S-XX-*
4"	31-FX-400/2R9S-XX-*
6"	31-FX-600/2R0S-XX-*

SIZED FOR 60 psi AIR SUPPLY	
SIZE	MODEL
1-1/2"	31-FX-150/2R6S4-XX-*
2"	31-FX-200/2R6S4-XX-*
2-1/2"	31-FX-250/2R7S4-XX-*
3"	31-FX-300/2R9S4-XX-*
4"	31-FX-400/2R9S4-XX-*
6"	31-FX-600/2R0S4-XX-*

* Must specify L or T port

NOTE: A number following the actuator model (Ex: 2R6S4), indicates the number of springs per side. For a standard (5 spring per side) actuator, the spring designation is omitted from the automated part number.

Actuators are sized for clean liquid surface with a specific gravity of 1 and at 70° F.

OPTIONS

DESCRIPTION	PART NO. SUFFIX	DESCRIPTION	PART NO. SUFFIX
Type 4 Solenoid	(A)	Type 4 Limit Switch (2) spdt	(A)
Type 7 Solenoid	(B)	Type 7 Limit Switch (2) spdt	(B)
Intrinsically Safe Solenoid	(C)	Intrinsically Safe Limit Switch	(C)

Other options available - call for details. Actuators are sized based on clean/clear fluid. Specify flow pattern when ordering. See automated part number matrix for complete part number and options.

SAMPLE PART # 31C-FX-150/2R6S4-XX-*

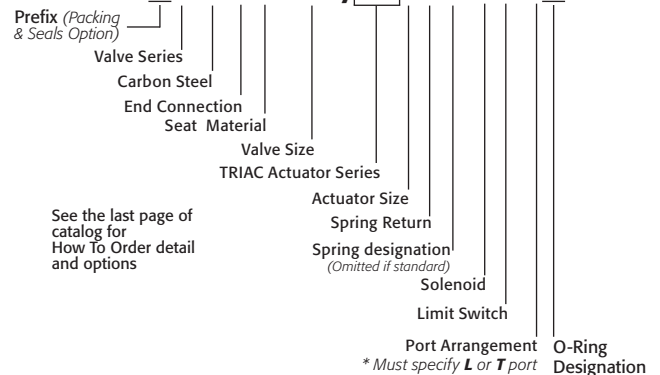

Refer to Series 31 IOM for all repair kit, seat and gasket part numbers.

See Automated Part Number Matrix for complete part number and options.



9955 International Blvd.
Cincinnati, Ohio 45246
www.atcontrols.com

PHONE (513) 247-5465
FAX (513) 247-5462
sales@atcontrols.com



Electric

Automated Ball Valve Package

Series 31 3-Way Flanged Ball Valve

- Sizes 1-1/2" - 6"
- 316SST or WCB
- Full Port Design
- ANSI Class 150
- 1-pc Ball & Stem
- Blowout Proof Stem
- RTFE Seats Standard
- "L" or "T" Port Option
- Trunnion Ball Design
- ISO 5211 Actuator Mounting Pad

STANDARDS

Design	ANSI/ASME B16.34
Flanged Ends	ANSI/ASME B16.5
Face-to-Face	(per factory's standard)
Pressure Testing	API 598
Mounting	ISO 5211
Safety Integrity	IEC 61508:2010; SIL 3
Marking System for Valves	MSS SP-25
Material Certification	EN 10204-3.1 MTR
Quality Assurance	ISO 9001:2015



Flanged 3-Way

For operating temperatures in excess of 158° F with an electric actuator, an extended bracket is required. Please consult factory for sizing information.

Class 150 Electric Assembly DIMENSIONS (IN)

VALVE SIZE	A	B	C	D	E	F
1-1/2"	9.02	14.68	7.20	13.31	5.00	10.43
2"	9.02	15.00	8.66	13.31	6.00	10.43
2-1/2"	10.20	16.79	11.06	14.49	7.00	11.26
3"	10.20	17.20	11.22	14.49	7.50	11.26
4"	10.20	18.94	13.70	14.49	9.00	11.26
6"	11.69	22.60	18.90	16.14	11.00	12.09

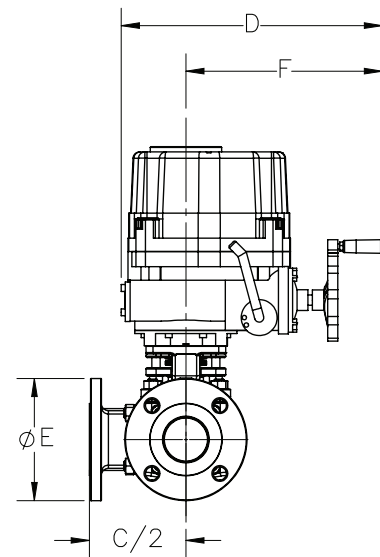
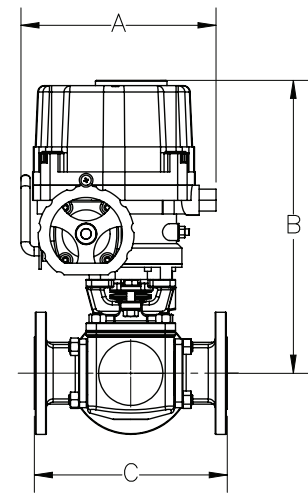

SERIES 31 3-Way 150# Flanged Direct Mount

ON-OFF	
SIZE	MODEL
1-1/2"	31-FX-150/WEC1-XX-*
2"	31-FX-200/WEC1-XX-*
2-1/2"	31-FX-250/WEE1-XX-*
3"	31-FX-300/WEF1-XX-*
4"	31-FX-400/WEF1-XX-*
6"	31-FX-600/WEH1-XX-*

MODULATING	
SIZE	MODEL
1-1/2"	31-FX-150/WEC2-XX-*
2"	31-FX-200/WED2-XX-*
2-1/2"	31-FX-250/WEF2-XX-*
3"	31-FX-300/WEG2-XX-*
4"	31-FX-400/WEG2-XX-*
6"	31-FX-600/WEH2-XX-*

* Must specify L or T port

Actuators are sized for clean liquid surface with a specific gravity of 1 and at 70° F.

OPTIONS

DESCRIPTION
24 VAC/24 VDC/220VAC
Feedback potentiometer

NOTE: Heater and thermostat standard
(2) auxiliary switches standard

Other options available - call for details
Actuators are sized based on clean/clear fluid.

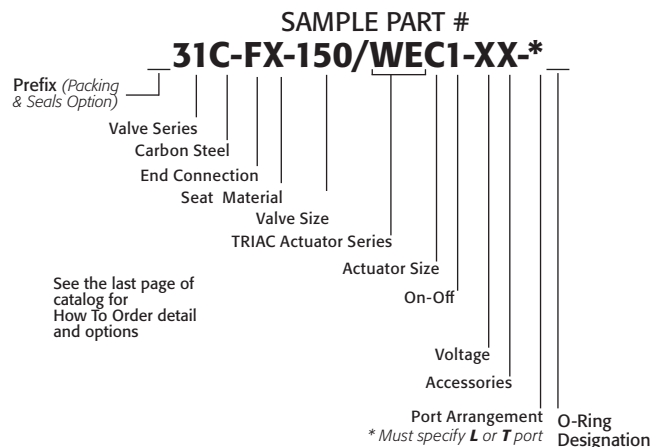

Refer to Series 31 IOM for all repair kit, seat and gasket part numbers.

See Automated Part Number Matrix for complete part number and options.

HOW TO ORDER: SERIES 31

Prefix	<i>blank</i> = Standard	
	F	Graphite Packing and Seals
	T	TFM Packing and Seals
Series	31	Flanged 3-way
Body Material	C	WCB Carbon Steel
	<i>blank</i>	CF8M Stainless Steel
Ends	F1	Class 150 Flanges
	F3	Class 300 Flanges
Size Full Bore Port Size	0150	1-1/2"
	0200	2"
	0250	2-1/2"
	0300	3"
	0400	4"
	0600	6"
Seat	X	RTFE Standard Seat
	P	Virgin PTFE Seat
	S	50/50 STFE Seat
	T	TFM®-1600 Seat
Option	X	Standard Options
Option	X	Standard Options
Port Arrangement	L	L-Port
	T	T-Port
O-Ring	<i>blank</i>	Standard FKM O-Ring
	K	FFKM Kalrez® 4079 O-Ring

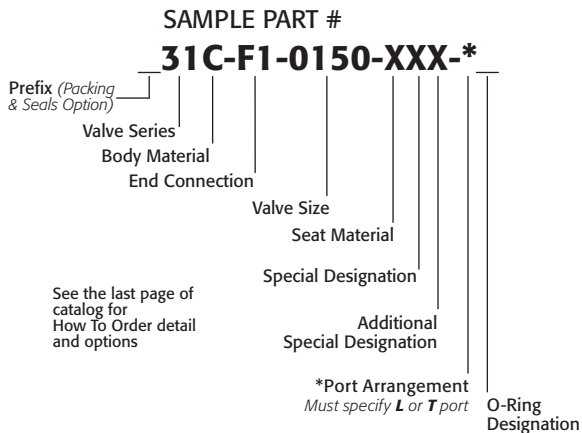

Refer to Series 31 IOM for all repair kit, seat and gasket part numbers.

See Part Number Matrix for itemized options

Other Products

Special Seats Balls and Seal Designs



180° Actuators



FM Approved Valves and Assemblies



Manual and automated valve assemblies for gas burner management applications and safety shutoff

Lockout Mounting Kits



Special Multi-Port Valves



Fusible Link Assemblies



Dual Valve Assemblies

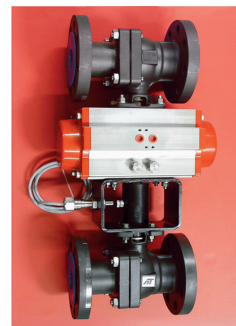

AT A-T Controls, Inc.

9955 International Blvd.
Cincinnati, Ohio 45246
www.atcontrols.com

PHONE (513) 247-5465
FAX (513) 247-5462
sales@atcontrols.com