

# EZ TF WL WT

## EZ Change Quick Connection System

### DESIGN FEATURES

- Nozzles can be changed in seconds without tools
- Three part nozzle, base, gasket and interchangeable tip
- Exclusive ramped engagement for efficient automatic alignment
- Threaded adapters will accommodate other standard BETE nozzles. Shut-off plugs are also available

### SPRAY CHARACTERISTICS

- Available in six standard tips: EZTF; EZWL; EZWT; EZFF\*; EZNF\*; EZSPN\*

**Flow rates:** 0.13 to 206 l/min

#### Spray Angle:

**EZTF:** 60°, 90° and 120° (Full or Hollow Cone, please specify when ordering), 150° & 170° (Full cone only), 180° (Hollow cone only)

**EZWL:** 30°, 60°, 90°, 120°

**EZWT:** 70° and 110°

\* See pages 92, 93

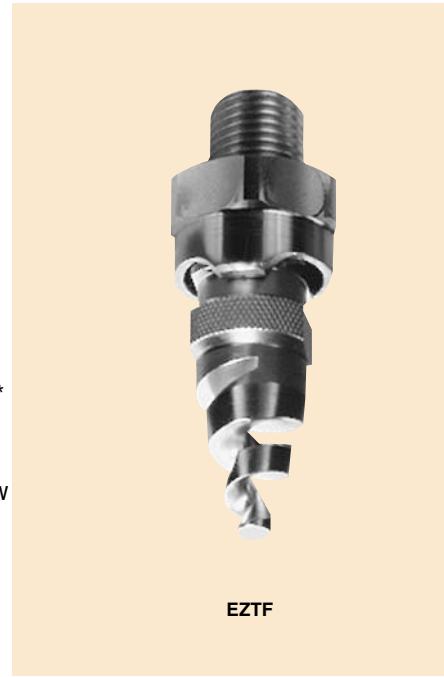

EZTF

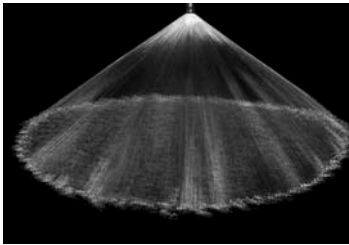

120° Full Cone



120° Hollow Cone

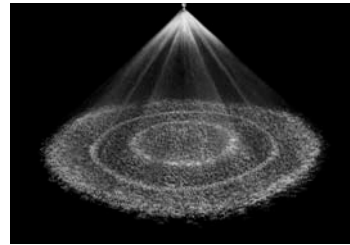

90° Full Cone Spiral

Dimensions are approximate. Check with BETE for critical dimension applications.

### EZTF Flow Rates and Dimensions

Full or Hollow Cone Spiral 60° (NN or V), 90° (FCN or M), 120° (FC or W), 150°, 170° or 180° (XW) Spray Angle 1/8" to 1/2" BSP or NPT

Pipe Size	Nozzle Number	K Factor	LITERS PER MINUTE @ BAR												Approx. Orifice Dia. (mm)	Approx. Assembly Dim. (mm)		Wt. (g)	
			0.3 bar	0.5 bar	0.7 bar	1 bar	2 bar	3 bar	5 bar	7 bar	10 bar	15 bar	20 bar	30 bar		Hex	Length		
1/8"	EZTF6	3.19	1.75	2.26	2.67	3.19	4.51	5.53	7.13	8.44	10.1	12.4	14.3	17.5	2.38	1/8"	22.4	41.4	62
	TO EZTF8	5.93	3.25	4.19	4.96	5.93	8.38	10.3	13.2	15.7	18.7	22.9	26.5	32.5	3.18				
1/2"	EZTF10	9.12	4.99	6.45	7.63	9.12	12.9	15.8	20.4	24.1	28.8	35.3	40.8	49.9	3.97	1/4"	22.4	44.5	62
	TO EZTF12	13.7	7.49	9.7	11.4	13.7	19.3	23.7	30.6	36.2	43.2	53.0	61.1	74.9	4.76				
1/4"	EZTF14	18.5	10.1	13.1	15.4	18.5	26.1	32.0	41.3	48.8	58.4	71.5	82.6	101	5.56	3/8"	22.4	46.0	74
	TO EZTF16	24.2	13.2	17.1	20.2	24.2	34.2	41.8	54.0	63.9	76.4	93.6	108	132	6.35				
1/2"	EZTF20	37.6	20.6	26.6	31.5	37.6	53.2	65.1	84.1	99.5	119	146	168	206	7.94	1/2"	22.4	47.5	82

$$\text{Flow Rate (l/min)} = K \sqrt{\text{bar}}$$

TF20 not available with 1/8" base

**Standard Materials:** Brass and Viton gaskets standard. 316 Stainless Steel available upon request.

Spray angle performance varies with pressure. Contact BETE for specific data on critical applications.

SPECIAL PURPOSE

TO ORDER: specify pipe size, connection type, nozzle number, spray angle, and material.

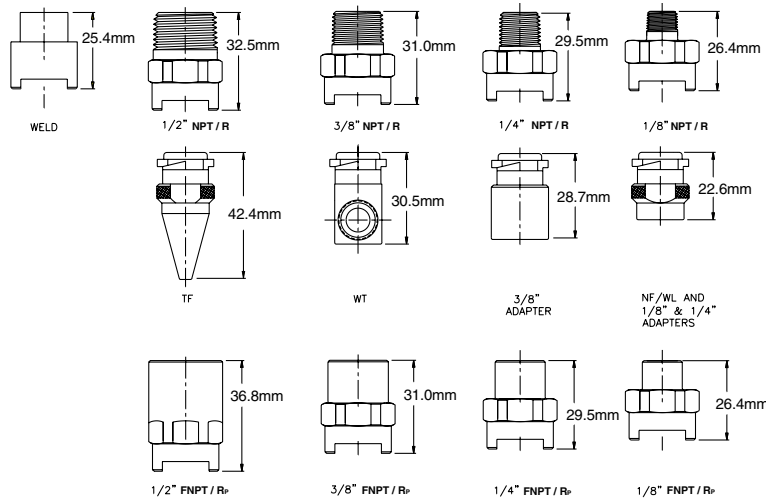

Dimensions are approximate. Check with BETE for critical dimension applications.

### EZWL Flow Rates and Dimensions

Full Cone Whirl 30°, 60°, 90°, 120° Spray Angle 1/8" to 1/2" BSP or NPT

Pipe Size	Nozzle Number	K Factor	LITERS PER MINUTE @ BAR							Approx. Orifice Dia (mm)	Approx. Assembly Dim. (mm)		Wt. (g)	
			0.2 bar	0.5 bar	0.7 bar	1 bar	2 bar	3 bar	5 bar		Hex	Length		
1/8"	EZWL 1/4	0.587	0.276	0.424	0.497	0.587	0.814	0.984	1.25	1.09	1/8"	22.4	41.4	62
	EZWL 1/2	1.17	0.551	0.848	0.993	1.17	1.63	1.97	2.50	1.40				
	EZWL 3/4	1.76	0.827	1.27	1.49	1.76	2.44	2.95	3.75	1.83				
TO	EZWL1	2.35	1.10	1.70	1.99	2.35	3.25	3.94	5.01	2.08	1/4"	22.4	44.5	62
	EZWL 1 1/2	3.52	1.65	2.54	2.98	3.52	4.88	5.91	7.51	2.77				
1/2"	EZWL2	4.70	2.21	3.39	3.97	4.70	6.51	7.87	10.0	3.18	3/8"	22.4	46.0	74
	EZWL3	7.05	3.31	5.09	5.96	7.05	9.76	11.8	15.0	3.96				
	EZWL4	9.40	4.41	6.78	7.95	9.40	13.0	15.7	20.0	4.78				
	EZWL5	11.7	5.51	8.48	9.93	11.7	16.3	19.7	25.0	5.16				
	EZWL6	14.1	6.62	10.2	11.9	14.1	19.5	23.6	30.0	5.56				

Flow Rate (l/min) = K (bar)<sup>0.47</sup>

Note: Square pattern also available

Standard Materials: 303 Stainless Steel, 316 Stainless Steel, Brass, and Viton gaskets standard.

### EZWT Flow Rates and Dimensions

Hollow Cone, Narrow (70°) and Wide (110°) Spray Angles 1/8" to 1/2" BSP or NPT

Pipe Size	Nozzle Number	K Factor	LITERS PER MINUTE @ BAR												Orifice Dia. (mm)	Approx. Assembly Dim. (mm)		Wt. (g)		
			0.3 bar	0.5 bar	0.7 bar	1 bar	2 bar	3 bar	5 bar	7 bar	10 bar	15 bar	20 bar	30 bar		Hex	Length			
1/8"	EZWT10	0.228	0.13	0.16	0.19	0.23	0.32	0.40	0.51	0.60	0.72	0.88	1.02	1.25	0.794	1/8"	22.4	41.4	62	
	EZWT12	0.273	0.15	0.19	0.23	0.27	0.39	0.47	0.61	0.72	0.87	1.06	1.22	1.50						
	EZWT18	0.410	0.23	0.29	0.34	0.42	0.58	0.71	0.92	1.09	1.30	1.59	1.83	2.25						1.19
	EZWT20	0.456	0.25	0.32	0.38	0.46	0.65	0.79	1.02	1.21	1.44	1.77	2.04	2.50						1.59
	EZWT27	0.615	0.34	0.44	0.52	0.62	0.87	1.07	1.38	1.63	1.95	2.38	2.75	3.37						1.19
	EZWT35	0.798	0.44	0.56	0.67	0.80	1.13	1.38	1.78	2.11	2.52	3.09	3.57	4.37						1.59
	EZWT40	0.912	0.50	0.65	0.76	0.91	1.29	1.58	2.04	2.41	2.88	3.53	4.08	4.99						1.98
	EZWT42	0.957	0.52	0.68	0.80	0.96	1.35	1.66	2.14	2.53	3.03	3.71	4.28	5.24						1.59
	EZWT48	1.09	0.60	0.77	0.92	1.09	1.55	1.89	2.45	2.89	3.46	4.24	4.89	5.99						1.59
	EZWT50	1.14	0.62	0.81	0.95	1.14	1.61	1.97	2.55	3.01	3.60	4.41	5.10	6.24						1.98
TO	EZWT53	1.21	0.66	0.85	1.01	1.21	1.71	2.09	2.70	3.20	3.82	4.68	5.40	6.62	1.98	1/4"	22.4	44.5	62	
	EZWT60	1.37	0.75	0.97	1.14	1.37	1.93	2.37	3.06	3.62	4.32	5.30	6.11	7.49	2.38					
	EZWT68	1.55	0.85	1.10	1.30	1.55	2.19	2.68	3.47	4.10	4.90	6.00	6.93	8.49	1.98					
	EZWT70	1.60	0.87	1.13	1.33	1.60	2.26	2.76	3.57	4.22	5.04	6.18	7.13	8.74	2.38					
	EZWT80	1.82	1.00	1.29	1.53	1.82	2.58	3.16	4.08	4.82	5.77	7.06	8.15	9.99	1.98					
	EZWT100	2.28	1.25	1.61	1.91	2.28	3.22	3.95	5.10	6.03	7.21	8.83	10.2	12.5	3.18					
	EZWT130	2.96	1.62	2.09	2.48	2.96	4.19	5.13	6.62	7.84	9.37	11.5	13.2	16.2	3.18					
	EZWT150	3.42	1.87	2.42	2.86	3.42	4.83	5.92	7.64	9.04	10.8	13.2	15.3	18.7	3.57					
	EZWT160	3.65	2.00	2.58	3.05	3.65	5.16	6.32	8.15	9.65	11.5	14.1	16.3	20.0	3.97					
	EZWT180	4.10	2.25	2.90	3.43	4.10	5.80	7.10	9.17	10.9	13.0	15.9	18.3	22.5	3.97					
1/2"	EZWT200	4.56	2.50	3.22	3.81	4.56	6.45	7.89	10.2	12.1	14.4	17.7	20.4	25.0	4.37	3/8"	22.4	46.0	74	
	EZWT220	5.01	2.75	3.55	4.19	5.01	7.09	8.68	11.2	13.3	15.9	19.4	22.4	27.5	3.97					
	EZWT240	5.47	3.00	3.87	4.58	5.47	7.73	9.47	12.2	14.5	17.3	21.2	24.5	30.0	4.76					
	EZWT260	5.93	3.25	4.19	4.96	5.93	8.38	10.3	13.2	15.7	18.7	22.9	26.5	32.5	5.16					
	EZWT270	6.15	3.37	4.35	5.15	6.15	8.70	10.7	13.8	16.3	19.5	23.8	27.5	33.7	5.16					
	EZWT280	6.38	3.49	4.51	5.34	6.38	9.02	11.1	14.3	16.9	20.2	24.7	28.5	34.9	5.56					
	EZWT300	6.84	3.74	4.83	5.72	6.84	9.67	11.8	15.3	18.1	21.6	26.5	30.6	37.4	5.56					
	EZWT340	7.75	4.24	5.48	6.48	7.75	11.0	13.4	17.3	20.5	24.5	30.0	34.7	42.4	5.56					
	EZWT350	7.98	4.37	5.64	6.67	7.98	11.3	13.8	17.8	21.1	25.2	30.9	35.7	43.7	5.95					
	EZWT400	9.12	4.99	6.45	7.63	9.12	12.9	15.8	20.4	24.1	28.8	35.3	40.8	49.9	7.14					

Flow Rate (l/min) = K √bar

Standard Materials: 303 Stainless Steel, 316 Stainless Steel, Brass, and Viton gaskets standard.

SPECIAL PURPOSE

CALL 413-772-0846  
Call for the name of your nearest BETE representative.