

TW

Tank Washing

DESIGN FEATURES

- Clog-resistant spiral design
- Energy efficient
- Compact design; fits small openings

SPRAY CHARACTERISTICS

- Easy to maintain
- Unique patterns that spray in opposing directions
- See LEM on page 25 for other tank-washing applications

Flow rates: 11.4 to 260 l/min

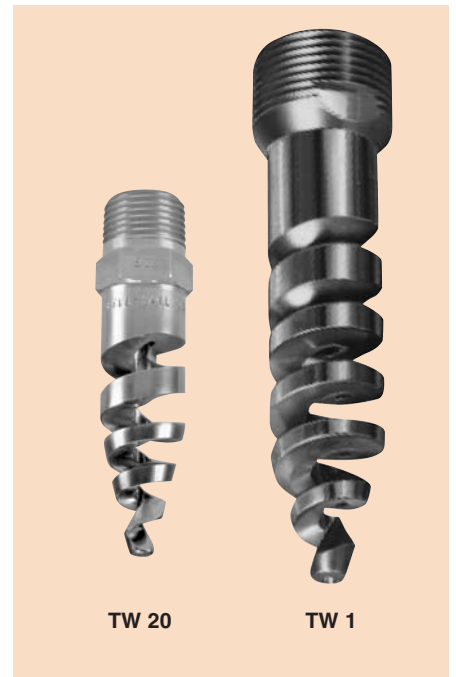

TW 20

TW 1

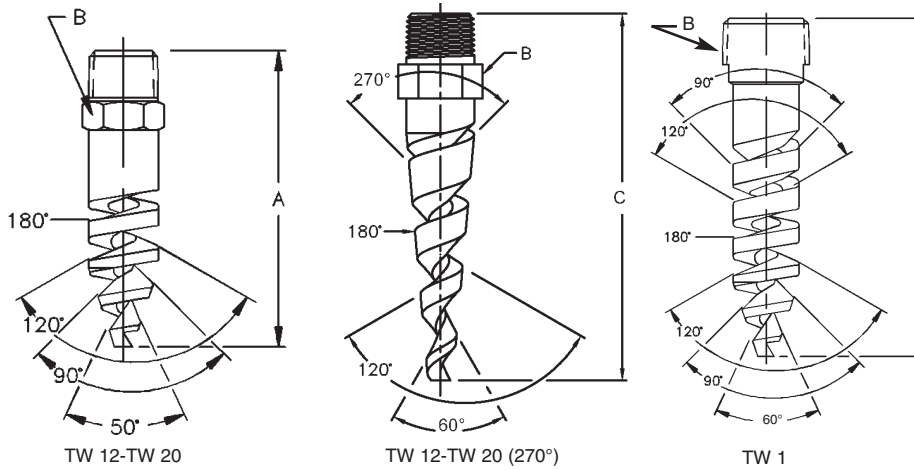

TW 12-TW 20

TW 12-TW 20 (270°)

TW 1

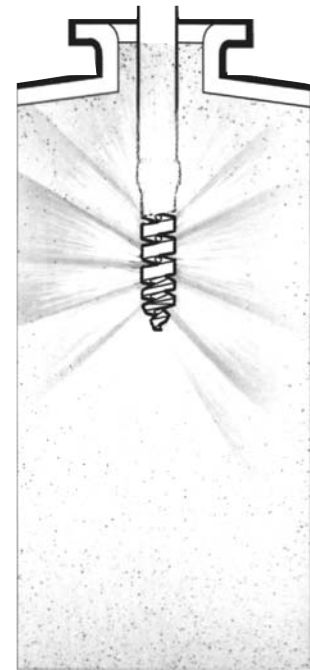

Tank Washing TW Coverage Chart

When Spraying at 2 - 3 bar

Pipe Size	Nozzle Number	Scrubbing Diameter (mm)	Rinsing Diameter (mm)
3/8	TW12	380	760
	TW14	460	1200
	TW16	610	1500
	TW20	910	2100
1	TW1	2400	6100

Dimensions are approximate. Check with BETE for critical dimension applications.

Tank Washing TW Flow Rates and Dimensions

TW 180° and 270° Spray Angles, 3/8" and 1" Pipe Sizes, BSP or NPT

Male Pipe Size	Nozzle Number	Available Spray Angles	K Factor	LITERS PER MINUTE						Approx. (mm)		Metal Only Dim. (mm)			Weight (g) Metal
				0.7 bar	1 bar	2 bar	3 bar	4 bar	5 bar	Orifice Dia	Free Pass. Dia.	A	B	C	
3/8	TW12	180°, 270°	13.7	11.4	13.7	19.3	23.7	27.3	30.6	4.83	3.30	73.0	17.5	92.2	49.6
	TW14	180°, 270°	18.5	15.4	18.5	26.1	32.0	36.9	41.3	5.59	3.30				
	TW16	180°, 270°	24.2	20.2	24.2	34.2	41.8	48.3	54.0	6.35	3.30				
	TW20	180°, 270°	37.6	31.5	37.6	53.2	65.1	75.2	84.1	7.87	3.30				
1	TW1	270°	116	97.2	116	164	201	232	260	14.2	5.08	28.6	146.1	298	

$$\text{Flow Rate (l/min)} = K \sqrt{\text{bar}}$$

Standard Materials: Brass, 316 Stainless Steel.

Spray angle performance varies with pressure. Contact BETE for specific data on critical applications.