

FINZ™

High Impact Fan Air Nozzle

DESIGN FEATURES

- Controlled wide uniform distribution and high impact coverage of compressed air
- Can be mounted individually or side-by-side for greater coverage
- Efficient air flow rates with unique eductor feature
- Safe operation—meets OSHA specifications for noise and deadhead pressure
- 1/4" male connection is molded to fit either NPT or BSP
- Up to 2dB quieter than competing designs

- Rugged construction of Ryton® or ABS plastic. Ryton® rated to 149°C at 3 bar
- Maximum operating pressure 7 bar

SPRAY CHARACTERISTICS

Spray pattern: Fan

Air Flow Rates: 7 to 65 Nm³/h at 0.7 to 6 bar

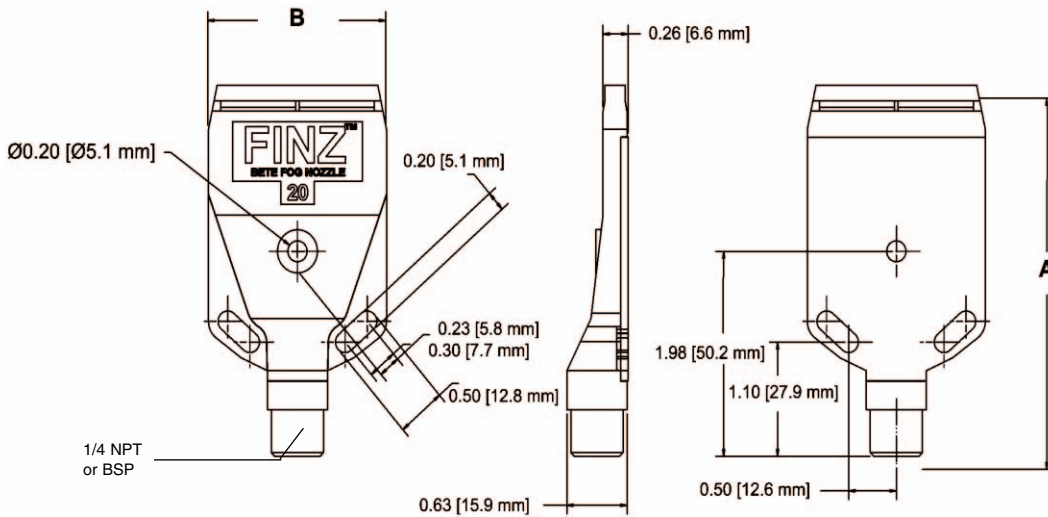

Dimensions are approximate. Check with BETE for critical dimension applications.

FINZ High Impact Air Nozzle

Male NPT BSP	Nozzle Number	Air Capacity Nm ³ /h				Approx. Dim. (mm)		Wt. (g)
		0.7 bar	2 bar	4 bar	6 bar	A	B	
1/4"	FZ20	7	12	19	26	91	47	28.3
	FZ29	11	21	32	43			
	FZ41	15	28	47	65			

Standard Materials: Ryton® and ABS plastic.

Ryton is a trademark of Phillips Petroleum company

SPECIAL PURPOSE

TO ORDER: specify pipe size, connection type, nozzle number and material.