

T100 Series Medium Pressure Models T100K & T100M

Maximum Flow Rate: 45 gpm (170.4 l/min)
Maximum Pressure: 3500 psi (241 bar)

Hydra-Cell[®]
Seal-less Pumps



T100 Series medium pressure model with
Nickel Aluminum Bronze pump head

**Available
to Meet
API 674!**

- Seal-less design eliminates leaks, hazards and the expense associated with seals and packing
- Low NPSH requirements allow for operation with a vacuum condition on the suction - positive suction pressure is not necessary
- Can operate with a closed or blocked suction line and run dry indefinitely without damage, eliminating downtime and repair costs
- Unique diaphragm design handles more abrasives with less wear than gear, screw or plunger pumps
- Hydraulically balanced diaphragms to handle high pressures with low stress
- Lower energy costs than centrifugal pumps
- Rugged construction for long life with minimal maintenance
- Compact design and double-ended shaft provide a variety of installation options

T100 Series Medium Pressure Performance

Capacities

Flow				Pressure	
Model	Max. Input rpm	Max. Flow		Maximum Inlet Pressure	
		gpm	l/min	500 psi (34 bar)	
		@ 3000 psi (207 bar)		Maximum Discharge Pressure	
T100K	450	45.0	170.4	T100K	3000 psi (207 bar)
		@ 3500 psi (241 bar)		T100M	3500 psi (241 bar)
T100M	450	38.0	143.8		

Consult factory when operating below 20 gpm (75.7 l/min).

Maximum Flow at Designated Pressure

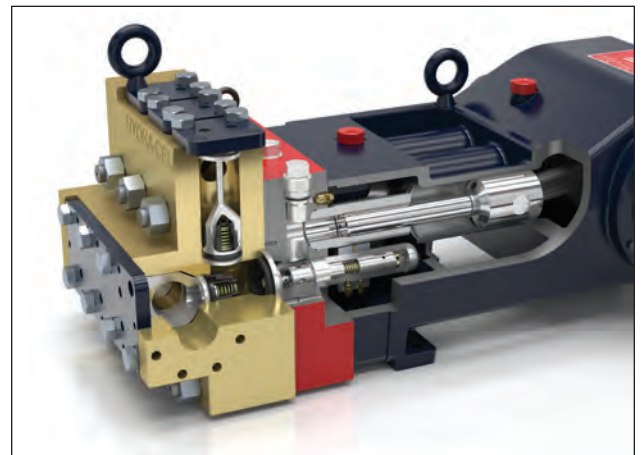
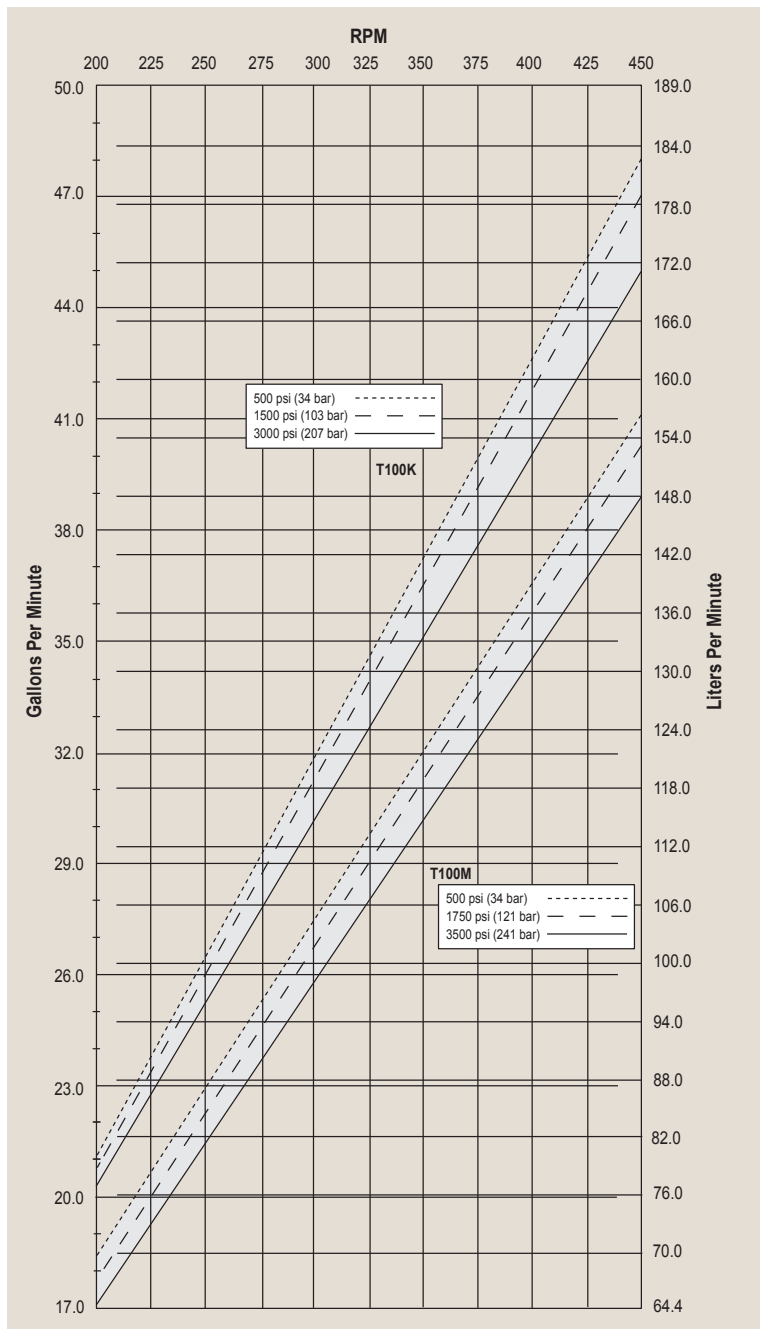

T100 Series pumps feature the Hydra-Cell seal-less design, eliminating clean-up costs from leaking seals or packing and protecting operators from dangerous fluids such as those containing hydrogen sulfide.

Due to Wanner Engineering continuous improvement practices, performance data and specifications may change without notice.

T100 Series Medium Pressure Specifications

Flow Capacities

Model	Pressure psi (bar)	rpm	gpm	l/min
T100K	3000 (207)	450	45.0	170.4
T100M	3500 (241)	450	38.0	143.8

Delivery

	Pressure psi (bar)	gal/rev	liters/rev
T100K	500 (34)	0.107	0.406
	1500 (103)	0.105	0.397
	3000 (207)	0.101	0.384
T100M	500 (34)	0.091	0.345
	1750 (121)	0.089	0.338
	3500 (241)	0.086	0.327

rpm

Maximum:	450
Minimum:	200 (Consult factory for speeds less than 200 rpm)

Maximum Discharge Pressure

Metallic Heads:	T100K	3000 psi (207 bar)
	T100M	3500 psi (241 bar)

Maximum Inlet Pressure

500 psi (34 bar)

Operating Temperature

Maximum:	180° F (82.2° C)
Minimum:	40° F (4.4° C)

Consult factory for temperatures outside this range

Maximum Solids Size

800 microns

Input Shaft

Left or Right Side

Inlet Ports

3-1/2 inch Class 300 RF ANSI Flange or
2-1/2 inch NPT

Discharge Ports

1-1/2 inch Class 2500 RTJ ANSI Flange or
1-1/2 inch NPT

Shaft Diameter

3 inch (76.2 mm)

Shaft Rotation

Reverse (bi-directional)

Oil Capacity

18 US quarts (17 liters)
10W30 standard-duty oil

Weight

Metallic Heads: 1100 lbs. (499 kg)

Fluid End Materials

Manifold:	Nickel Aluminum Bronze (NAB)
	316L Stainless Steel
Diaphragm/Elastomers:	FKM
	Buna-N
Valve Spring Retainer:	17-7 Stainless Steel
	PVDF
	Polypropylene
	316 SST
Check Valve Spring:	Hastelloy C
	Elgiloy
Valve Disc/Seat :	Tungsten Carbide
	17-4 Stainless Steel
	Hastelloy C

Power End Materials

Crankshaft:	Forged Q&T Alloy Steel
Crankcase:	Ductile Iron
Bearings:	Spherical Roller/Journal (main)

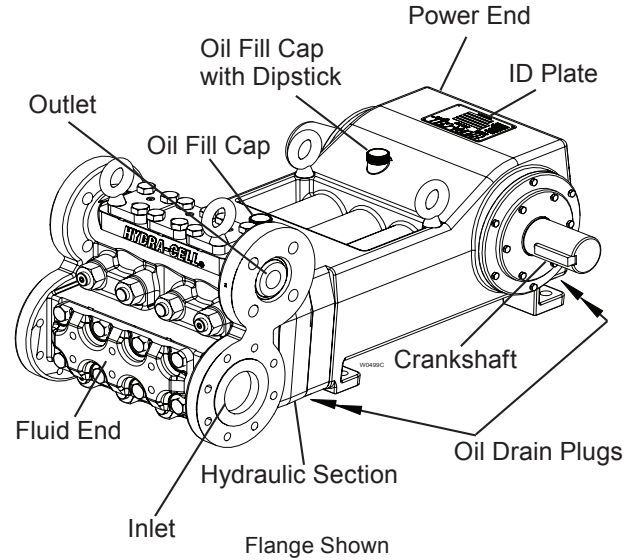

Net Positive Suction Head (NPSHr)

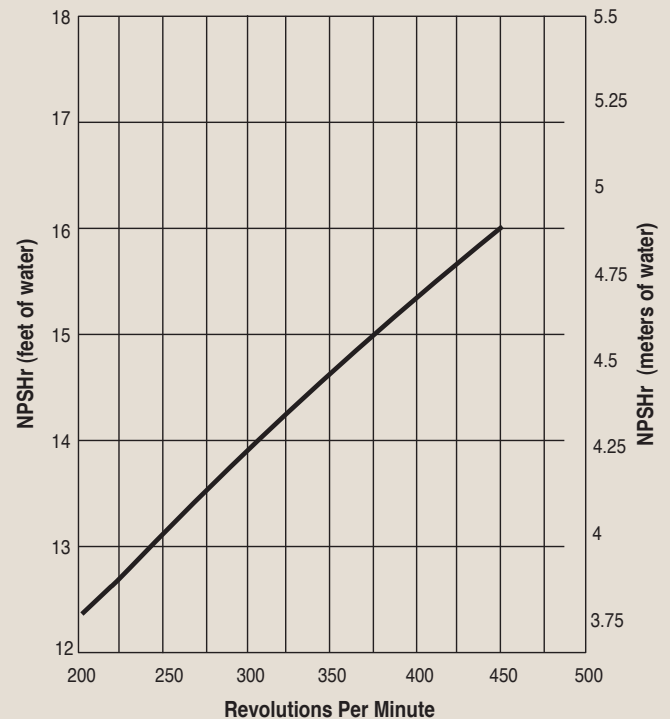

Calculating Required Horsepower (kW)*

$$\frac{\text{gpm} \times \text{psi}}{1,460} = \text{electric motor hp}^*$$

$$\frac{\text{lpm} \times \text{bar}}{511} = \text{electric motor kW}^*$$

* hp (kW) is required application power.

Attention!

When sizing motors with variable speed drives (VFD): It is very important to select a motor and a VFD rated for constant torque inverter duty service and that the motor is rated to meet the torque requirements of the pump throughout desired speed range.

T100 Series Medium Pressure Dimensions

Threaded Version Inches (mm)

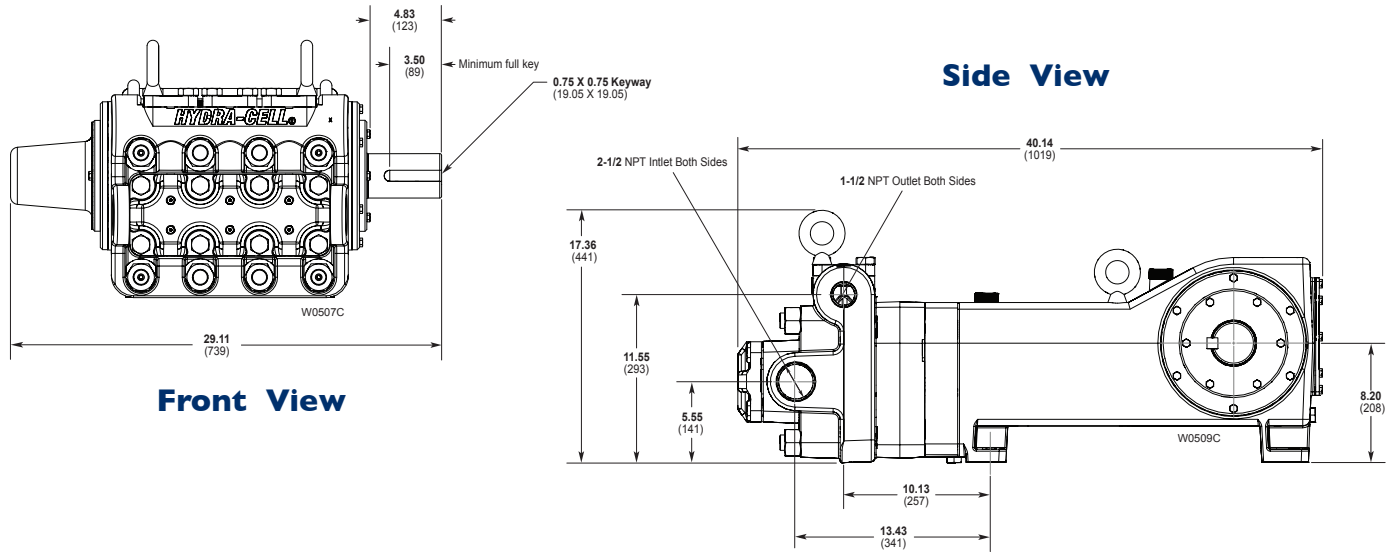

Flanged Version Inches (mm)

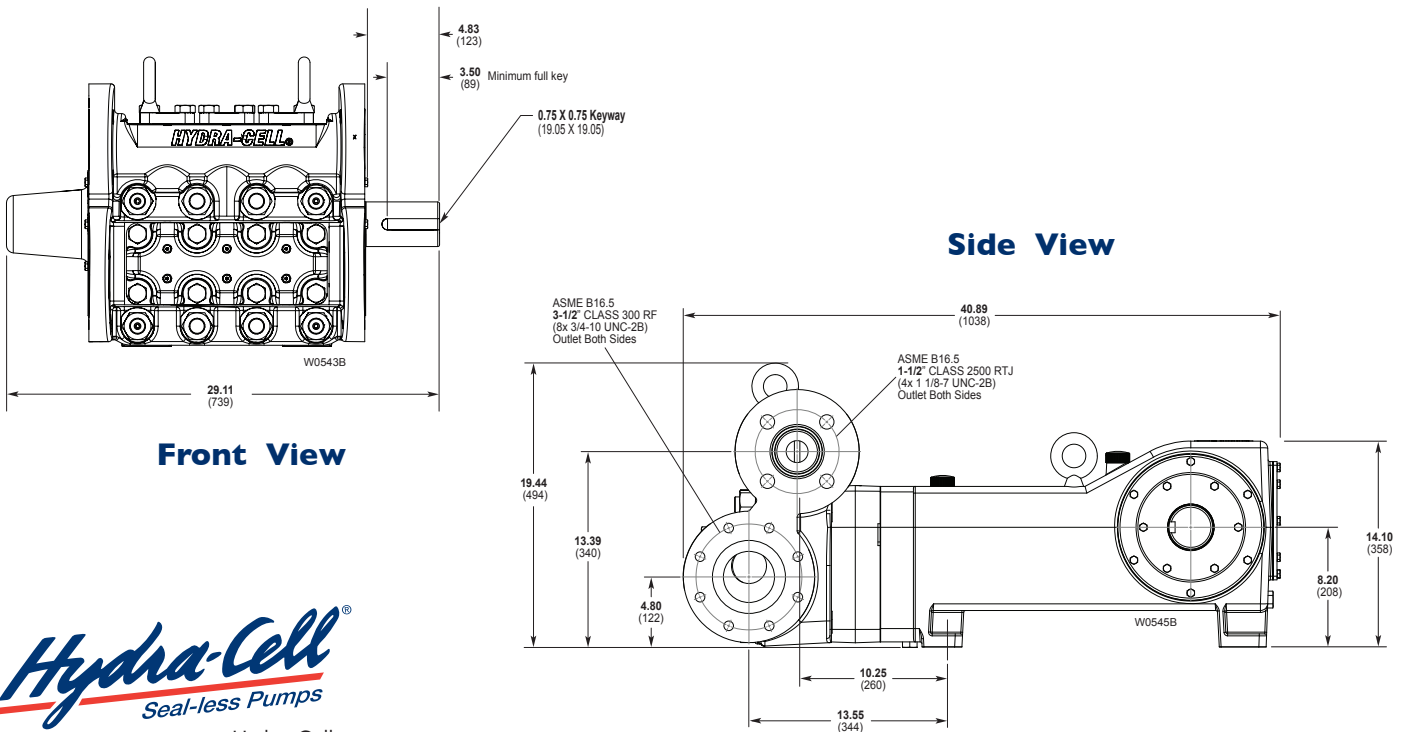

www.Hydra-Cell.com

Wanner Engineering, Inc.

World Headquarters & Manufacturing

1204 Chestnut Avenue
 Minneapolis, MN 55403 USA
 Tel: (612) 332-5681 • FAX: (612) 332-6937
 Toll Free FAX (USA only) (800) 332-6812
 Email: sales@wannereng.com
 www.hydra-cell.com

Wanner International Ltd.

8 & 9 Fleet Business Park
 Sandy Lane, Church Crookham,
 Hampshire GU52 8BF England
 Tel: +44 (0) 1252 816847
 FAX Tel: +44 (0) 1252 629242
 Email: sales@wannerint.com
 www.hydra-cell.eu

Wanner Pumps Ltd.

Flat A, 21 F
 Chatham Commercial Building
 399 Chatham Road North
 Hunghom, Kowloon, Hong Kong
 Tel: (852) 3428-6534
 FAX: (852) 3188-9145
 Email: sales@wannerpumps.com