

GLOBAL GEAR® PUMPS



- Tough Pumps with Field Proven Reliability

 **Tuthill**

Engineered Solutions

GLOBAL GEAR® PROCESS PUMP

GlobalGear was introduced in 2001, and since then more than 9,000 pumps have been shipped to locations all over the world.

INDUSTRIES AND APPLICATIONS Where GlobalGear Pumps Have Been Applied

Chemical Processing: Polymers, resins, adhesives, glues, solvents, sodium hydroxide, magnesium hydroxide, phosphoric acid, plasticizers, pigments, catalysts, additives, polyvinyl alcohol, silicone oils

Petrochemical: API 676 rotary pumps, asphalt, grease, lube oil, motor oil, turbine oil, fuel oil, bunker C heavy fuel oil, diesel fuel, synthetic oils, odorant, additives, drilling support systems

Printing: Inks and pigments

Personal Products: Soap, detergents, surfactants, perfume, paraffin wax

Polyurethane Foam Manufacturing: Polyol, isocyanate, fire retardants

Pulp & Paper: Starch, clay coatings, tall oil

Paints & Coatings: Paint, stains, varnish, enamel, solvents

Construction Materials: Asphalt, filled asphalt, caulk, concrete additives

Agricultural Chemicals: Biocides, herbicides, urea

Aviation: Kerosene, Skydrol, glycol

Food & Beverage: Soybean oil, canola oil, hot fry oil, high fructose corn syrup, sucrose, glucose, molasses, honey, liquid sugars, chocolate, tallow, lard, peanut butter, caramel coloring, mustard

Energy & Power: Biodiesel, glycerin, waste oil

Package Systems: Hydraulic oil, compressor oil, heat transfer fluids, hot oil, glycol

CUSTOMIZING Your Global Gear Pump

GlobalGear Pumps are versatile and can be customized to meet the requirements of specific applications.

Optional Features:

- Relief Valves
- Seal Choices
- Heat Jackets
- Oversized and High Pressure Flanges
- Abrasive Fluid
- Special Construction
- High Temperature Construction

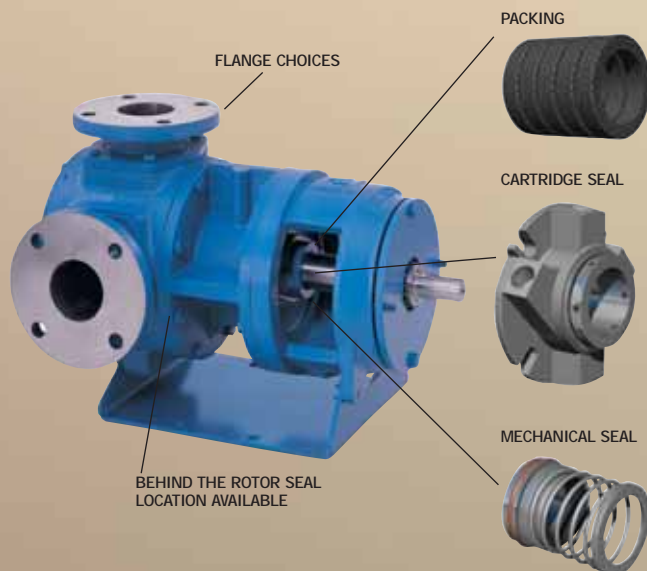

Tuthill tough. And flexible—for the way you work.

GlobalGear® builds on a time-tested design and more than 80 years of gear pump engineering experience. Capable of tackling the toughest high-viscosity applications, the GlobalGear® Process Pump handles everything from bulk transfer, chocolate and asphalt, to high-temperature fluids and chemical processing.

GlobalGear® uses robust pump design together with tougher and stronger materials to make the pump last longer. When maintenance is required, in-line seal maintenance and back pull-out features are available to make the servicing of the pumps quicker and easier.

The result?

An unbeatable pump that offers unparalleled performance.

GLOBALGEAR® PUMPS



The Inside Reliability Story Behind GLOBALGEAR® *The Pump designed for you!*

Tuthill's GlobalGear® was developed based on customer input, and customer input in the process industries clearly points to the need for better gear pump reliability and specifically better seal reliability. The opportunity for better reliability is created by the situation that many pumps applied on viscous liquids are fundamentally designed for packing and later adapted to mechanical seals. In many cases, the seals being selected were designed for use with water-like liquids. Pumps designed for packing combined with mechanical seals designed for thin liquids are no match to offer extended reliability with demanding viscous liquid applications.

GlobalGear® design features for extended seal life include:

- Oversized shaft and bearing diameters in sizes 120 thru 550
- Large bore size for stuffing boxes
- Pressurized fluid paths for seal lubrication
- Options for viscous liquid duty seals

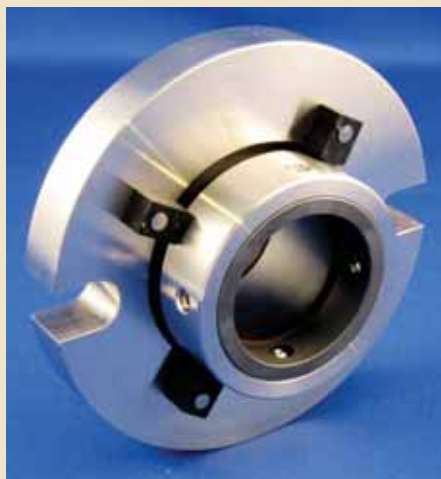

TUFFSEAL™



HEAVY DUTY SLURRY SEAL

GlobalGear® Materials and Size Address a **WIDER RANGE OF APPLICATIONS.**

SPECIFICATIONS

CAST IRON AND CARBON STEEL

Model	Max RPM	Nominal Flow Rate			
		USGPM		M ³ /HR	
GG015	1800	15 @	1750 RPM	2.8 @	1450 RPM
GG030	1800	30 @	1750 RPM	5.7 @	1450 RPM
GG050	1500	38 @	1150 RPM	6.9 @	920 RPM
GG070	1500	50 @	1150 RPM	9.1 @	920 RPM
GG080	1500	60 @	1150 RPM	10.9 @	920 RPM
GG090	1500	75 @	1150 RPM	13.7 @	920 RPM
GG120	1200	75 @	780 RPM	20.0 @	920 RPM
GG130	1000	100 @	780 RPM	27.0 @	920 RPM
GG200	1000	135 @	640 RPM	31.0 @	640 RPM
GG210	800	140 @	520 RPM	32.0 @	520 RPM
GG250	640	200 @	640 RPM	45.4 @	640 RPM
GG550*	500	550 @	500 RPM	124.5 @	500 RPM

Pressures to 200 psi (13.8 bar)
 Temperatures to 600°F (316°C)
 Viscosities to 1,000,000 ssu (220,000 cst)

*Pressures to 150 PSI (10 bar)
 *Temperatures to 400°F (204°C)

CAST STEEL

Model	Max RPM	Nominal Flow Rate			
		USGPM		M ³ /HR	
GG130	1000	100 @	780 RPM	27.0 @	920 RPM
GG250	640	200 @	640 RPM	45.4 @	640 RPM
GG550*	500	550 @	500 RPM	124.5 @	500 RPM

Pressures to 200 psi (13.8 bar) *Pressures to 150 PSI (10 bar)
 Temperatures to 500°F (316°C) *Temperatures to 400°F (204°C)
 Viscosities to 1,000,000 ssu (220,000 cst)

STAINLESS STEEL

Model	Max RPM	Nominal Flow Rate			
		USGPM		M ³ /HR	
GG015	1200	10 @	1150 RPM	1.8 @	920 RPM
GG030	1200	20 @	1150 RPM	3.7 @	920 RPM
GG080	1000	40 @	780 RPM	9.1 @	780 RPM
GG130	640	65 @	520 RPM	14.8 @	520 RPM
GG210	520	110 @	420 RPM	25.0 @	420 RPM
GG250**	520	160 @	520 RPM	36.3 @	520 RPM

Pressures to 150 psi (10.3 bar) **Pressures to 100 psi (6.9 bar)
 Temperatures to 500°F (260°C)
 Viscosities to 1,000,000 ssu (220,000 cst)

GlobalGear® Pumps are **TOUGHER AND MORE RELIABLE.**

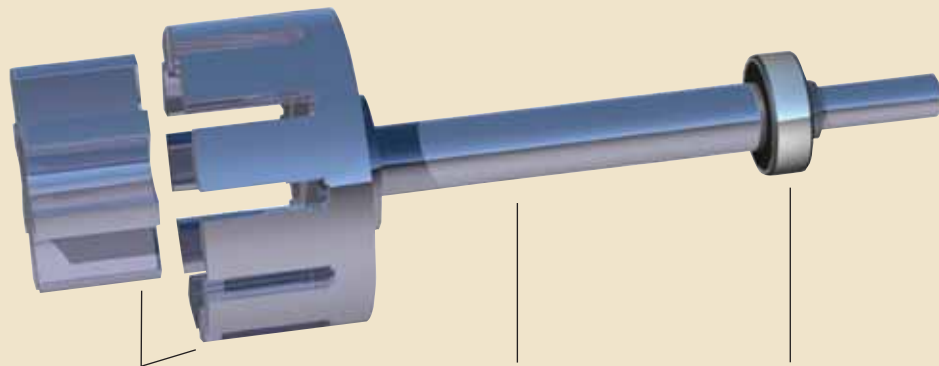

TOUGH GEARS

The rotor and idler gears are made of tough materials, which can handle the stresses of high-viscosity and high-pressure operation. No need for steel rotor upgrade.

PATENTED LUBRICATION FEATURE

Revolutionary lubrication method extends overall life by reducing friction.

STRONG SHAFT DESIGN

Models employ high-strength shaft materials. This, along with oversized shaft diameters, ensures a strong, reliable shaft.

ROBUST BEARING

Maintenance Free
 Lube for Life

Introducing the **HG VERSION GLOBALGEAR®**, for the toughest of tough services.

THE CHALLENGE...Provide a pump that will:

- Handle side loads of belt drive and allow for the sheave to be mounted directly on the pump input shaft
- Handle thrust loads associated with high system pressure
- Handle cold starts where the temperature drops to minus 20°F
- Withstand operation in a high vibration environment
- Design for five year life with only scheduled preventative maintenance lubrication

Tuthill answers with the HG set of severe services upgrades:

- Interference fit, paired single row bearings capable of 80,000 hours B-10 life
- Heavy duty hard face slurry type seals
- Extra shaft length to accommodate belt sheave
- Cartridge style drive module for bearing and seal renewal in minutes by a non-specialized crew

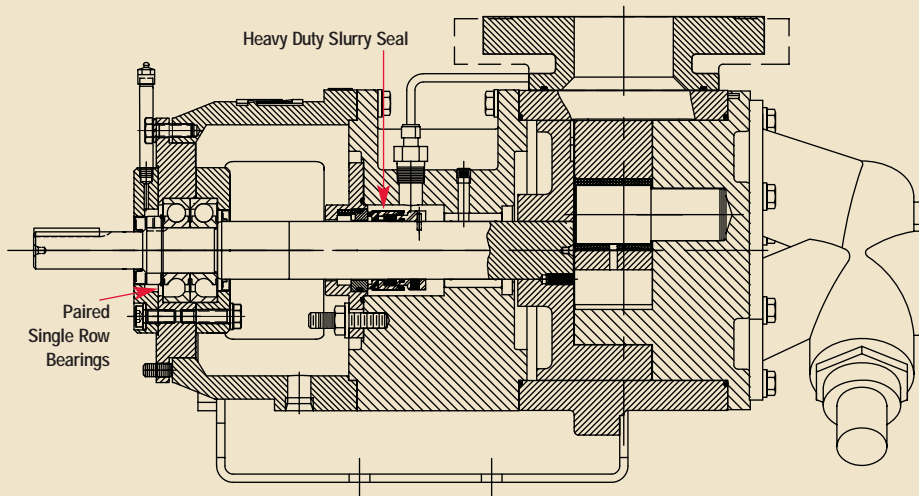

BACK PULL-OUT

The back pull-out design greatly reduces down-time for service—the pump can be repaired without disturbing piping or shaft alignment.

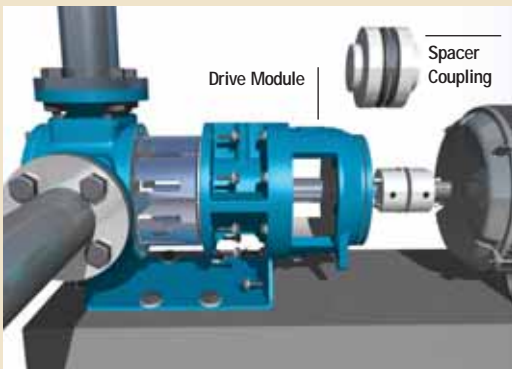

Downtime

- A. Typical time to replace complete pump
- B. Typical time to replace GlobalGear® drive module

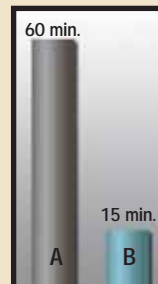



www.tuthill.com

*For additional information, please visit
the online GlobalGear Technical Library at:
www.tuthill.com/GlobalGear*

Online Technical Library Includes

- Performance Curves
- Service Manual
- Sample Guide Specifications
- Engineering Data Pack with Dimensions
and Design Information

To find an authorized distributor, visit www.tuthill.com

Tuthill Pump Group
12500 South Pulaski Road
Alsip, Illinois 60803 USA
phone: 708-389-2500

Tuthill United Kingdom
Birkdale Close
Manners Industrial Estate
Ilkeston, Derbyshire DE7 8YA England
phone: 44.115.932.5226

Tuthill Europe
Parc industriel Wavre Nord
Avenue Vésale, 30 - 1300 Wavre - Belgium
phone: 32 10 22 83 34

Tuthill China
88 Jia Xiu Road
Nan Xiang Town Jia Ding District
Shanghai, P.R.C. 201802 China
phone: 86.21.6917.1999

Engineered Solutions