

Automatic Self-Cleaning Strainers

2596 2"-8"

Pipeline
Strainer

Cast
Construction

Permanent
Media

Eaton's Model 2596 Automatic Self-cleaning Cast Pipeline Strainers are available in 2", 3", 4", 6", and 8" sizes. A 4"L size is also available which allows for greater flow rates. The Model 2596 is recognized across industries for its continuous flow, simplified maintenance, and worry-free operation.



Model 2596 2", 3", and 4" Sizes

Model 2596 4"L, 6", and 8" Sizes

FEATURES / BENEFITS

- Flow rates up to 1800 gpm (409 m³/hr)
- A broad selection of screen options
- Automatic backwashing for operator-free service and minimal backwash effluent
- Exclusive idL™ Seal for leak free service
- Unitized modular assembly for easy maintenance
- Cenpeller technology for more efficient and complete backwashing
- Cast iron or stainless steel construction
- High-efficiency motor

OPTIONS

25 micron and 40 micron stainless steel element with a flow rate of up to 800 gpm

The Eaton Model 2596 Automatic Self-cleaning Strainer is designed for the continuous removal of entrained solids from liquids in pipeline systems.

With an automated control system monitoring the strainer operation, cleaning is accomplished by an integral backwash system. A small portion of the screen element is isolated and cleaned by reverse flow while the remaining screen area continues to strain—providing uninterrupted flow. This efficient design uses only a small amount of the liquid being strained to carry debris away from the strainer element.

The Model 2596 features the idL™ shaft seal that positively prevents leakage from the backwash shaft at the top of the strainer. This unique quad seal keeps the exterior of the strainer dry and prevents

external leakage or weeping of the process media down the sides of the strainer.

The 2" to 8" size strainers feature Eaton's Cenpeller™ technology, which directs incoming liquid into a circular flow—forcing the debris to lay up against the surface of the strainer element in a way that makes backwashing easier and more efficient and greatly reduces the need for manual cleanouts.



To simplify maintenance the Model 2596 features a unitized modular assembly. The motor, gear reducer, and the internal operating mechanism are housed within the strainer cover and lift off as a unit. This makes all components easily accessible and reduces associated maintenance costs.

EATON

Powering Business Worldwide

Model 2596 2" to 8" Automatic Self-Cleaning Strainers

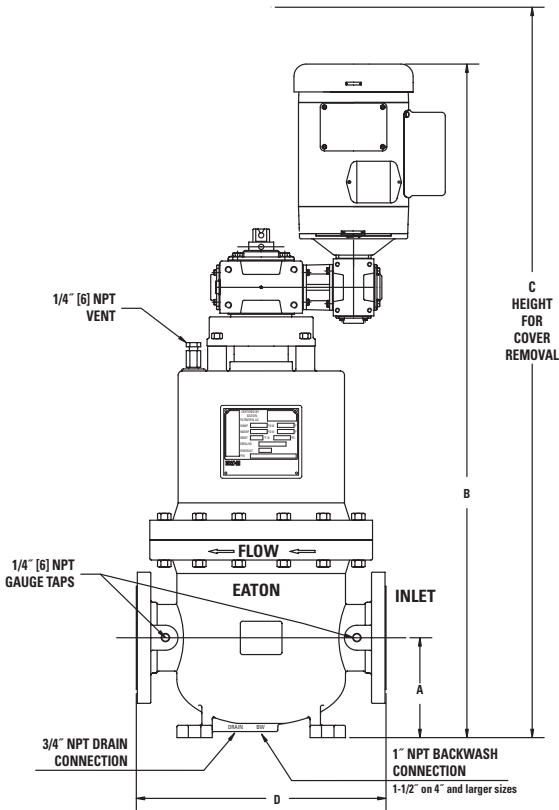

Model 2596 2" - 8" Flow Rates

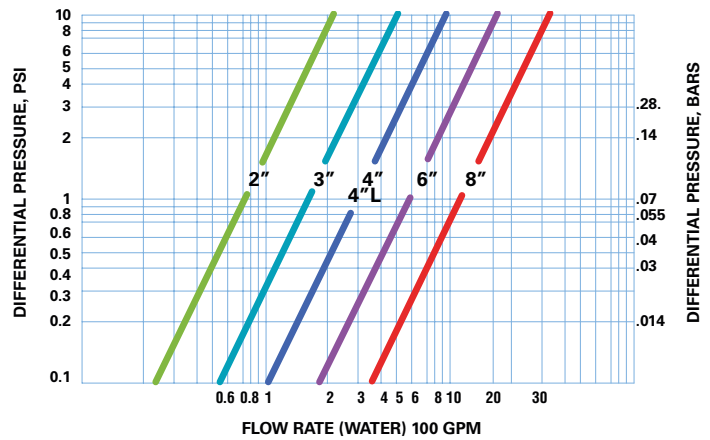

Pressure drop data indicates results to be expected with clean water, under normal flows with standard straining media and in clean strainer.

Size	Approximate Dimensions (in)				Approximate Weight (lb)		
	A	B	C	D	Dry	Wet	Cover
2"	6	40½	42½	15	328	382	164
3"	6	40½	42½	15	344	399	164
4"	7	42	44	15	353	413	164
4"L	8	52	55	23½	805	998	438
6"	8	55	58	23½	836	1081	438
8"	8	55	58	23½	901	1129	438

Dimensions are for reference only. For installation purposes, request certified drawings.

STRAINER MEDIA

DuraWedge® Element

DuraWedge is a nonclogging, rugged stainless steel element for the most demanding applications. It is constructed from V-shaped profile wire. A wide range of opening sizes is available.



Convuluted Element

A sturdy, economical stainless steel element for general service use. Available perforated openings of 1/8", 1/16", and 1/32". Available mesh sizes of 20, 40, 60, 80, 100, 150, and 200 mesh.



Low Micron Element

Stainless steel with a high degree of permeability will substantially lower pressure differential, increase flow capacity, and extend the filter life. Sintered mesh construction prevents media migration into processed product. Available in 25µ and 40µ retention.



C_v Factors 25µ

Size	Value
2"	76
3"	156
4"	233
4L"	272
6"	528
8"	708

C_v Factors 40µ

Size	Value
2"	77
3"	163
4"	260
4L"	288
6"	605
8"	887

Application Limits

- Cast Iron Class 125 Flange (-20° to 150 °F) 200 psi (2" - 8")
- Cast 316 Stainless Steel Class 150 Flange (-20° to 100 °F) 275 psi (2" - 4")
- 6" - 8" Fabricated Class 150 Flange (150 °F) 150 psi

North America
44 Apple Street
Tinton Falls, NJ 07724
Toll Free: 800 656-3344
(North America only)
Tel: +1 732 212-4700

China
No. 3, Lane 280,
Linhong Road
Changning District, 200335
Shanghai, P.R. China
Tel: +86 21 5200-0099

Europe/Africa/Middle East
Auf der Heide 2
53947 Nettersheim, Germany
Tel: +49 6205 2094-0

Singapore
100G Pasir Panjang Road #07-08
Singapore 118523
Tel: +65 6825-1668

Friedensstraße 41
68804 Altlußheim, Germany
Tel: +49 6205 2094-0
An den Nahewiesen 24
55450 Langenlonsheim, Germany
Tel: +49 6704 204-0

Brazil
Rua Clark, 2061 - Macuco
13279-400 - Valinhos, Brazil
Tel: +55 11 3616-8400