

# SUMMIT™

ANSI Dimension Model 2196

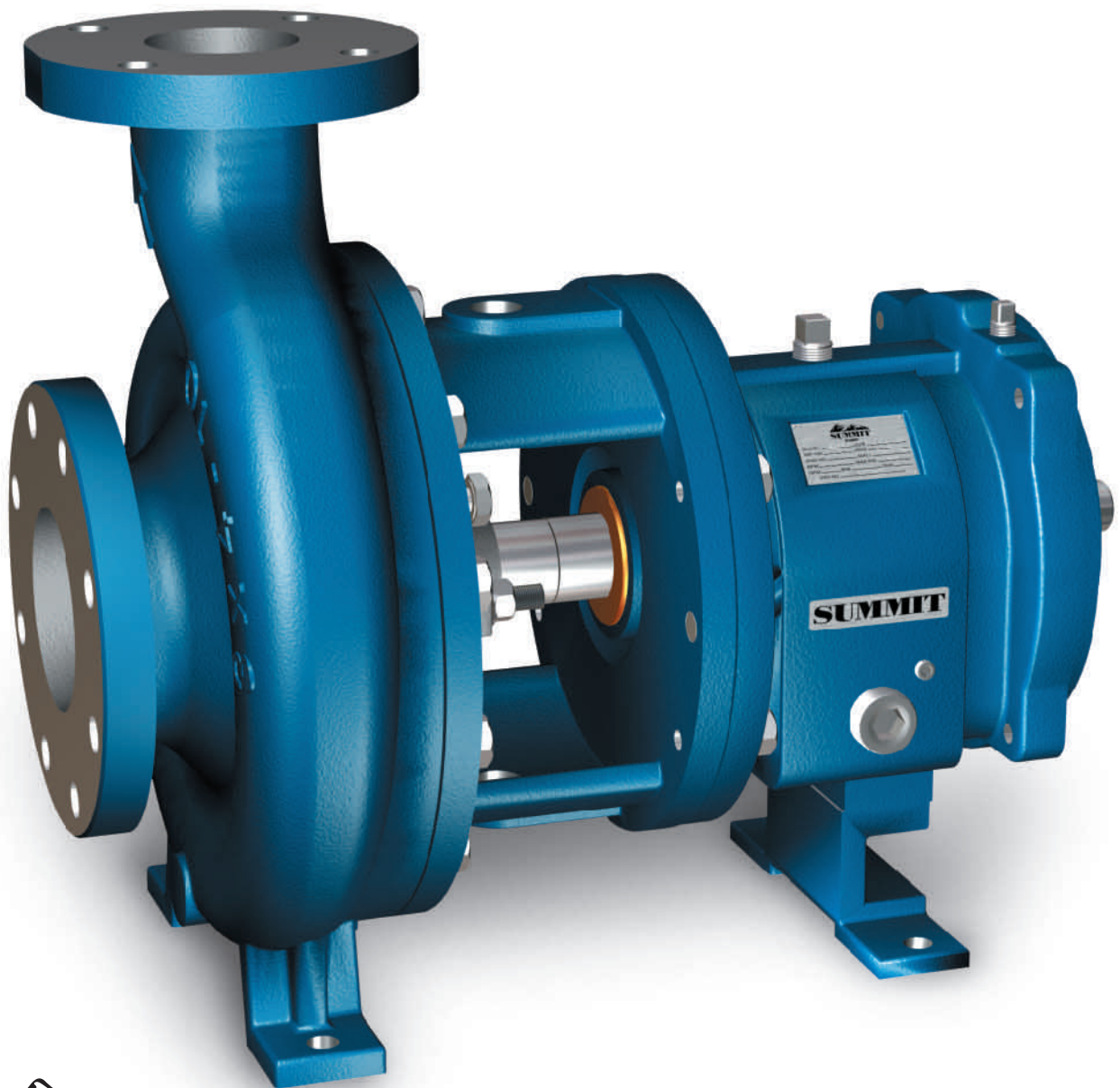

**SUMMIT™**  
**PUMP**

# ANSI Dimension Model 2196

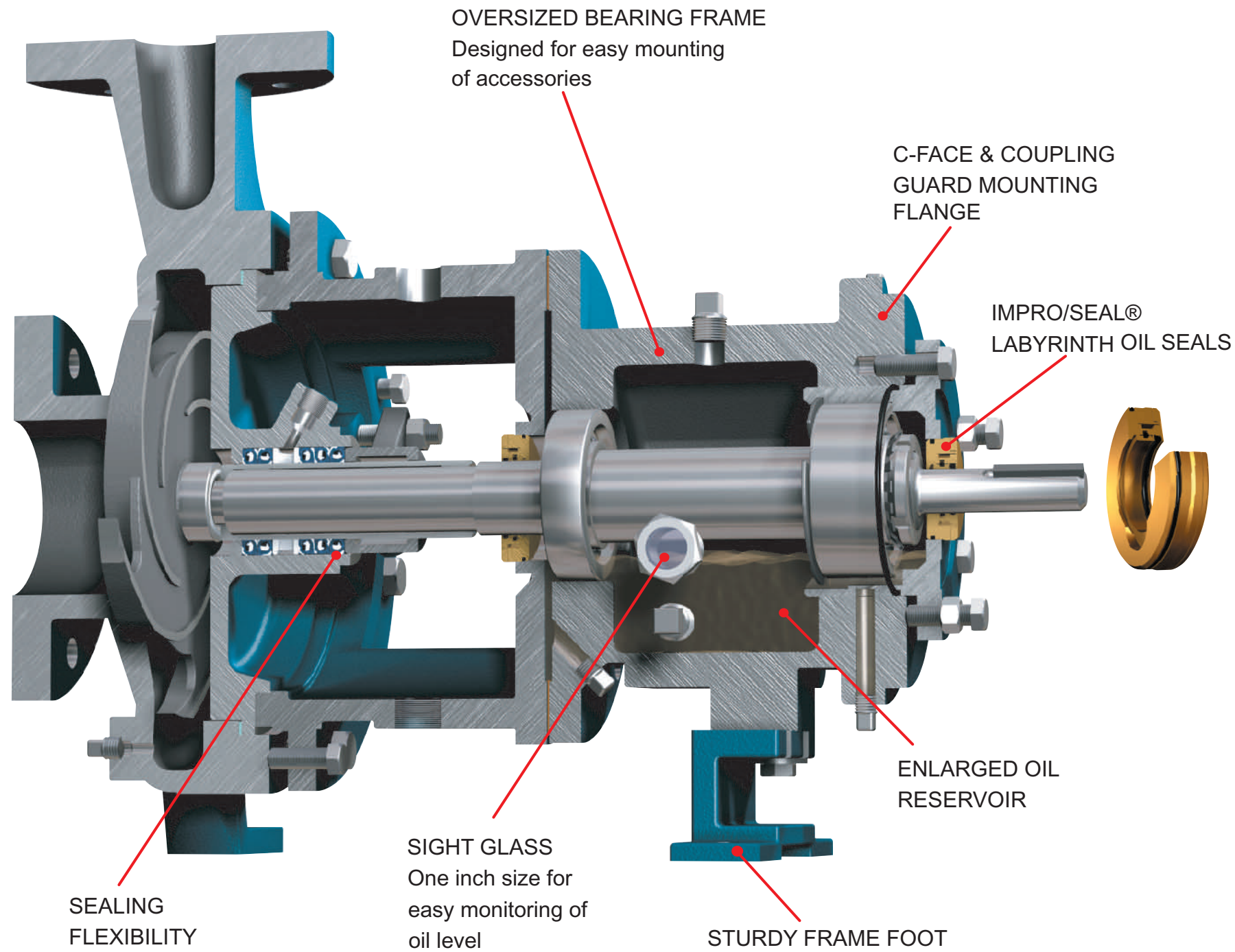

OPTIONAL: FINNED-TUBE OIL COOLER Can be installed in field

# Performance / Sizing Charts

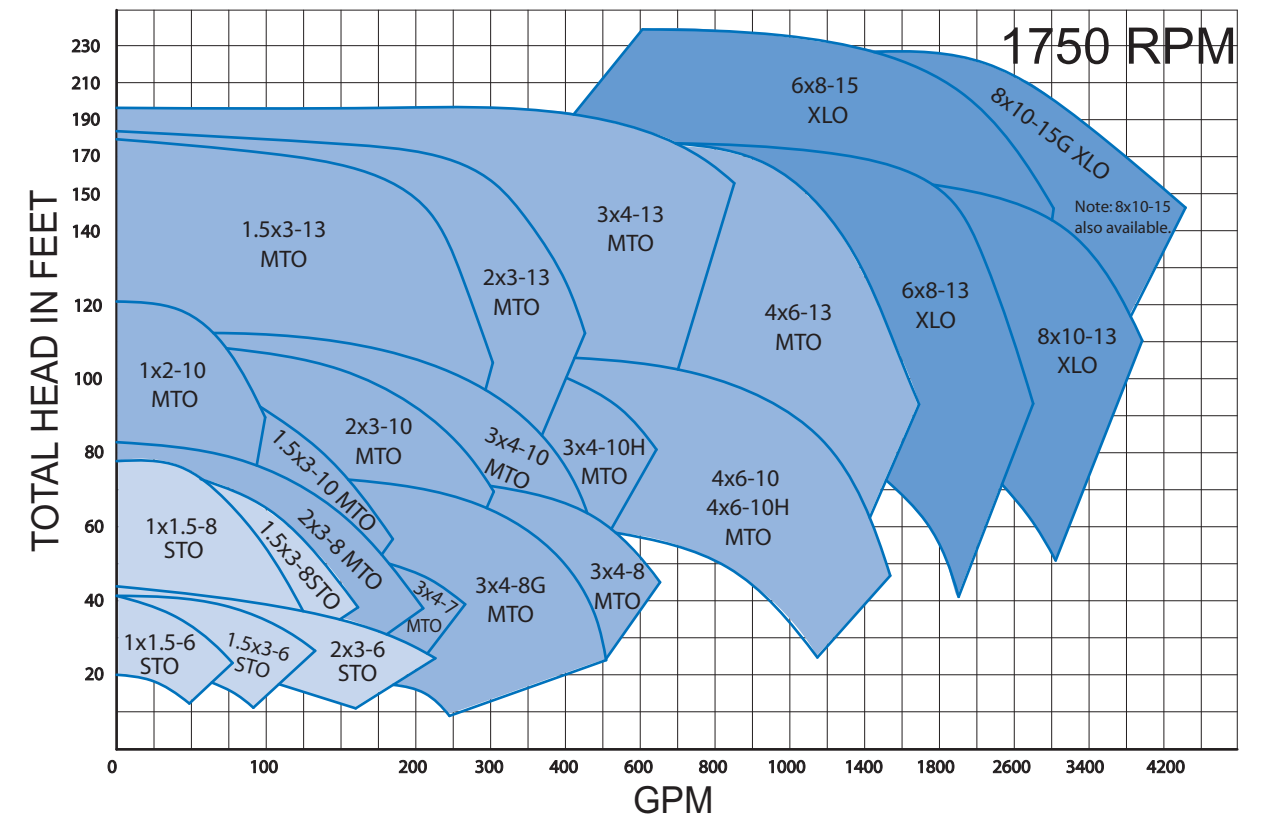
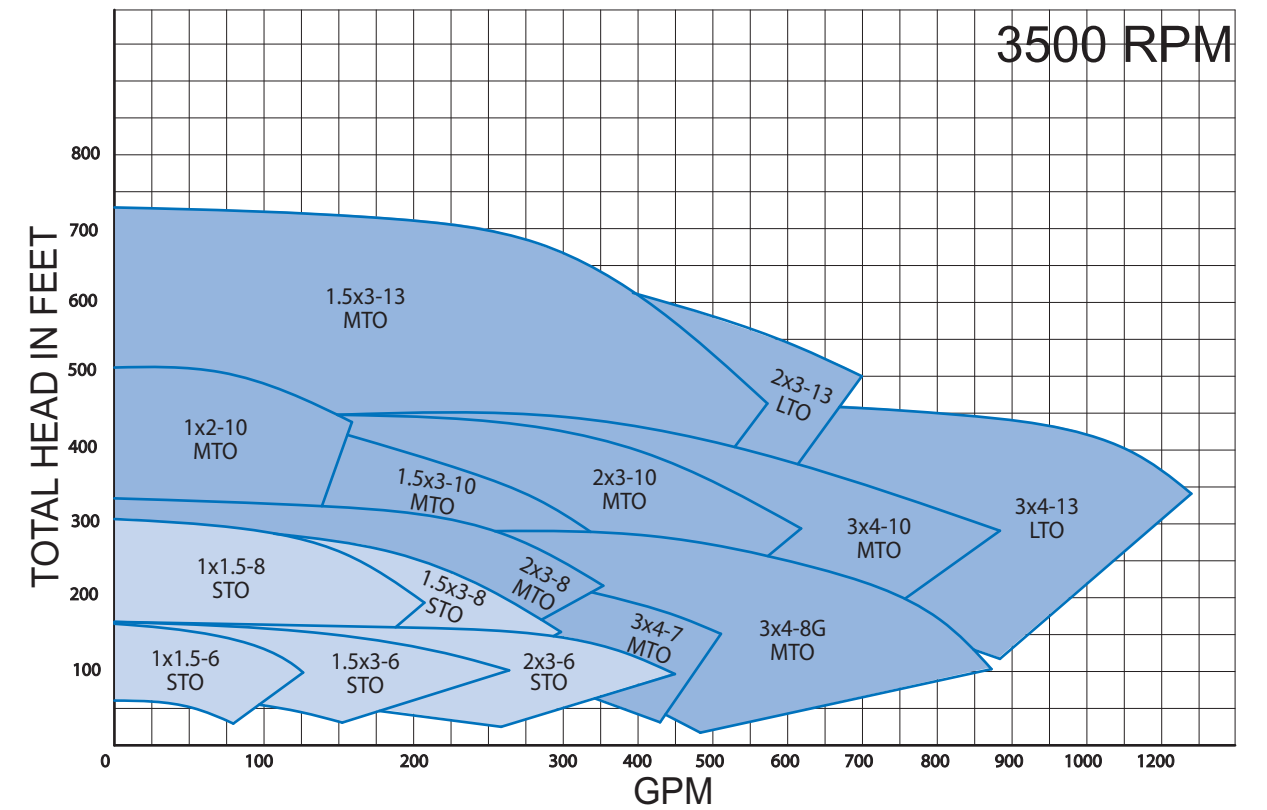

Note: Performance & Sizing curves are provided for reference only. For specific information, contact your distributor or the manufacturer.

# Model 2196 Interchangeability and Dimensional Data

Model 2196 STO

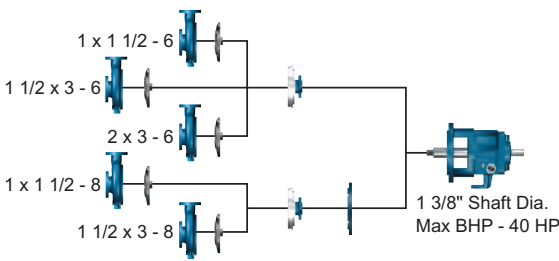

Model 2196 MTO

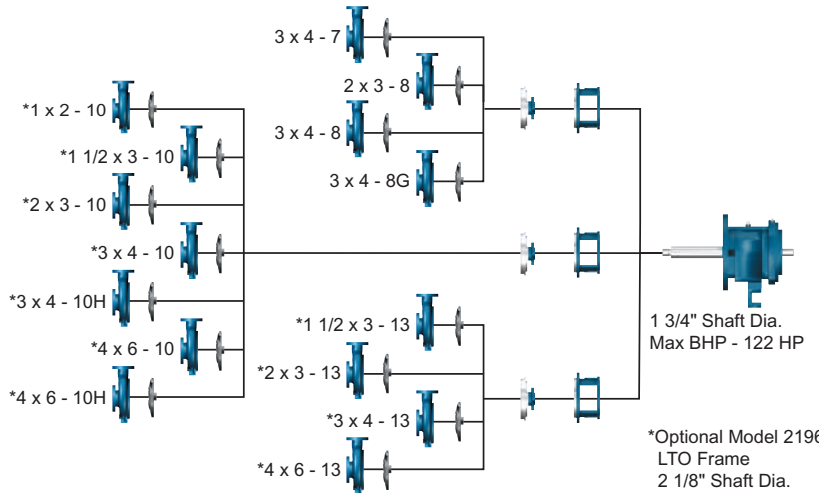

Model 2196 XLO

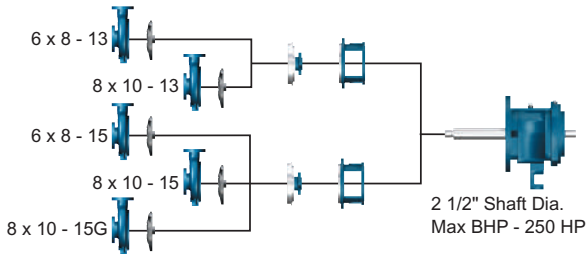

\*Optional Model 2196 LTO Frame  
2 1/8" Shaft Dia.  
Max BHP - 200 HP

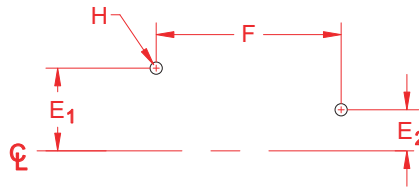
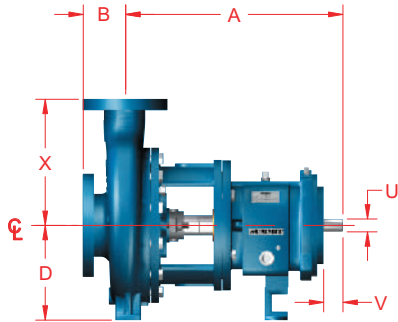

Pump Frame	ANSI	Size		Pump Dimensions													
				X	D	B	A	SP	Foot Pattern				Shaft				
		DIS	SUC						IMP	E1	E2	F	H	U	KEYWAY	V	
STO	AA	1	1.5	6	6 1/2	5 1/4	4	13 1/2	3 3/4	3	0	7 1/4	5/8	.875	3/16 X 3/32	2	
	AB	1.5	3	6													
		2	3	6													
		1	1.5	8													
MTO or LTO	A60	2	3	8	8 1/4	4	19 1/2	3 3/4	4 7/8	3 5/8	12 1/2	5/8	MTO 1.125	MTO 1/4X1/8	2 5/8		
	A70	3	4	8												11	
	A70	3	4	8G												11	
	A05	1	2	10												8 1/2	
	A50	1.5	3	10												8 1/2	
	A60	2	3	10												9 1/2	
	A70	3	4	10												11	
	A40	3	4	10H												12 1/2	
	A80	4	6	10												13 1/2	
	A80	4	6	10H												13 1/2	
LTO	A20	1.5	3	13	10	14 1/2	6	27 7/8	5 1/4	8	4 1/2	18 3/4	7/8	LTO 1.875	LTO 1/2X1/4	4	
	A30	2	3	13													11 1/2
	A40	3	4	13													12 1/2
	A80	4	6	13													13 1/2
XLO	A90	6	8	13	14 1/2	6	27 7/8	5 1/4	8	4 1/2	18 3/4	7/8	2.375	5/8 X 5/16	4		
	A100	8	10	13												18	
	A110	6	8	15												18	
	A120	8	10	15												19	
	A120	8	10	15G	19												